

# MxPro<sup>4</sup>



## Installation & Commissioning

The operation and functions described in this manual are available from Software Version Mx4100-023, Mx4200-023 and Mx4400-023 onwards.

# Specifications:

| Item   | Specification Details  |  |  |  |   |
|--|--|--|--|--|---|
|  | <i>Mx-4100 / Mx-4100/L</i>   | <i>Mx-4200 / Mx-4200/D</i>   | <i>Mx-4400 / Mx4400/D</i>  | <i>Mx-4400/LE</i>  | <i>Mx-4800</i>  |
| Enclosure  | Steel IP30   | Steel IP30   | Steel IP30   | Steel IP30   | Steel IP30  |
| Dimensions H x W x D mm  | 320 x 345 x 88<br>340 x 368 x 125 (/L)   | 475 x 450 x 125<br>475 x 450 x 190 (/D)  | 475 x 450 x 125<br>475 x 450 x 190 (/D)  | 950 x 450 x 190  | 950 x 450 x 190   |
| Weight (excluding batteries)   | 5Kg / 6Kg (/L)   | 10.5Kg / 12Kg (/D)   | 10.5Kg/ 12Kg (/D)  | 20Kg   | 23Kg  |
| Temperature  | -5°C to 40°C   | -5°C to 40°C   | -5°C to 40°C   | -5°C to 40°C   | -5°C to 40°C  |
| Humidity   | 95 % Max   | 95 % Max   | 95 % Max   | 95 % Max   | 95 % Max  |
| Cable Entries (20mm knockouts)   | 7x top and 7x top rear<br>14x top / 7x top rear (/L)   | 18x top, 9x top rear and<br>2x bottom<br>36x top, 9x top rear (/D)                                     | 18x top, 9x top rear and<br>2x bottom<br>36x top, 9x top rear (/D)                                       | 36x top, 9x top rear and<br>2x bottom                                      | 36 x top, 9 x top rear<br>and 2 x bottom                      |
| Mains Supply   | 230V AC<br>50 - 60Hz<br>0.4A   | 220-240V AC<br>50 - 60 Hz<br>1 A   | 220-240V AC<br>50 - 60 Hz<br>1 A   | 220-240V AC<br>50 - 60 Hz<br>1 A   | 220-240V AC<br>50 - 60 Hz<br>2 A                              |
| Battery Capacity   | 24V 4Ah Internal (min)<br>24V 7Ah Internal (max)<br>(Mx-4100)<br>24V 12Ah Internal (max)<br>(Mx-4100/L). | 24V 4Ah Internal (min)<br>24V 17Ah Internal (max)<br>(Mx4200)<br>24V 38Ah Internal (max)<br>(Mx4200/D) | 24V 4Ah Internal (min)<br>24V 17Ah Internal (max)<br>(Mx-4400)<br>24V 38Ah Internal (max)<br>(Mx-4400/D) | 24V 4Ah Internal (min)<br>24V 48Ah Internal (max)<br>(2x 24Ah in parallel) | 2x 24V 4Ah Internal<br>(min)<br>2x 24V 38Ah Internal<br>(max) |
| Charging Current   | 0.4A<br>Temperature<br>Compensated   | 2.4A<br>Temperature<br>Compensated   | 2.4A<br>Temperature<br>Compensated   | 2.4A<br>Temperature<br>Compensated   | 2 x 2.4A<br>Temperature<br>Compensated                        |
| Max Battery Resistance (+/-10%)  | 2.6Ω   | 1.5Ω   | 1.5Ω   | 1.5Ω   | 1.5Ω  |
| Power Supply   | On-board 24V DC, 2A<br>High Efficiency Switched<br>Mode  | Separate 24V DC, 4A<br>Off-Line<br>Switched Mode   | Separate 24V DC, 5A<br>Off-Line<br>Switched Mode   | Separate 24V DC, 5A<br>Off-Line<br>Switched Mode                           | 2x Separate 24V DC, 5A<br>Off-Line<br>Switched Mode           |
| I <sub>max(a)</sub> = I <sub>max(b)</sub>  | 1.4A   | 2.6A   | 2.6A   | 2.6A   | 2.6A  |
| Output Voltage <sup>1</sup>  | 18.0V – 32.0V  | 18.0V – 28.0V  | 18.0V – 28.0V  | 18.0V – 28.0V  | 18.0V – 28.0V   |
| Ripple (Vpkpk)   | 3.5V   | 1.0V   | 1.0V   | 1.0V   | 1.0V  |
| Number of Fire Zones   | 100 max<br>(250 when networked)  | 200 max, across 2 loops<br>(1000 when networked)   | 200 max, across 4 loops<br>(1000 when Networked)   | 200 max, across 4 loops<br>(1000 when Networked)                           | 400 max, across 8 loops<br>(1000 when Networked)              |
| Number of Loops  | 1  | 1 to 2   | 1 to 4   | 1 to 4   | 2 to 8  |
| Devices per Loop   | Apollo 126 detector/call points per loop (max)<br>Hochiki 127 detector/call points per loop (max)        |  |  |  |   |
| Loop Current <sup>2</sup> (max. / Loop)  | 400mA quiescent<br>500mA alarm   | 400mA quiescent<br>500mA alarm   | 400mA quiescent<br>500mA alarm   | 400mA quiescent<br>500mA alarm   | 400mA quiescent<br>500mA alarm                                |
| Protocols  | Apollo: S90, XP95, Discovery, Explorer & Hochiki ESP   |  |  |  |   |
| Sounder <sup>2</sup> Outputs   | 2 x 1A Programmable  | 2 x 1A Programmable  | 4 x 1A Programmable  | 4 x 1A Programmable  | 8 x 1A Programmable   |
| Relay Outputs  | 2 x 1A 30VAC/DC (max)<br>10mA 5V (min)<br>Programmable   | 2 x 1A 30V AC/DC<br>(max) 10mA. 5V<br>(min) Programmable   | 2 x 1A 30V AC/DC<br>(max) 10mA. 5V (min)<br>Programmable   | 2 x 1A 30V AC/DC<br>(max) 10mA. 5V (min)<br>Programmable                   | 4 x 1A 30V AC/DC<br>(max) 10mA. 5V (min)<br>Programmable      |
| Open Collector Outputs   | 2 x Programmable<br>10mA 30V DC (max)  | 2 x Programmable<br>10mA 30V DC (max)  | 2 x Programmable<br>10mA 30V DC (max)  | 2 x Programmable<br>10mA 30V DC (max)                                      | 4 x Programmable<br>10mA 30V DC (max)                         |
| Digital Outputs  | ---  | 6 x Programmable   | 6 x Programmable   | 6 x Programmable   | 12 x Programmable   |
| Auxiliary Supply Output <sup>2</sup>   | 24V DC, 500mA  | 24V DC, 500mA  | 24V DC, 500mA  | 24V DC, 500mA  | 2 x 24V DC, 500mA   |
| Event Log  | 1000 Event & Diagnostic + 500 Fire   |  |  |  |   |
| As our policy is one of constant product improvement the right is therefore reserved to modify product specifications without prior notice |  |  |  |  |   |

<sup>1</sup> Minimum/maximum specifications for the AUX, and Sounder outputs. Detector Loop voltage is not dependant on AC or battery voltage.

<sup>2</sup> Total output current and panel load should not to exceed I<sub>max(a)</sub>.

# Table of Contents

|          |   |           |
|----------|---|-----------|
| <b>1</b> | <b>INTRODUCTION</b>                                       | <b>6</b>  |
| 1.1      | STANDARDS   | 6         |
| 1.2      | CAUTIONS AND WARNINGS                                     | 7         |
| 1.3      | DESCRIPTION   | 7         |
| 1.4      | EN54 FUNCTIONS  | 8         |
| 1.5      | EN54 OPTIONAL FEATURES WITH REQUIREMENTS                  | 9         |
| 1.6      | INSTALLATION APPROVALS                                    | 10        |
| 1.6.1    | Fire System Installations                                 | 10        |
| 1.6.2    | Wiring Regulations  | 10        |
| <b>2</b> | <b>INSTALLATION</b>                                       | <b>11</b> |
| 2.1      | IDENTIFICATION OF PARTS                                   | 11        |
| 2.1.1    | Mx-4100   | 11        |
| 2.1.2    | Mx-4200 & Mx-4400   | 11        |
| 2.1.3    | Mx-4400/LE  | 12        |
| 2.1.4    | Mx-4800   | 12        |
| 2.2      | INSTALLING THE Mx-4100 ENCLOSURE                          | 13        |
| 2.2.1    | Removing and Replacing the Enclosure Cover of the Mx-4100 | 13        |
| 2.2.2    | Removing the Chassis                                      | 13        |
| 2.2.3    | Mounting the Enclosure                                    | 13        |
| 2.2.4    | Remounting the Chassis                                    | 13        |
| 2.2.5    | Recommended Cable Routing Arrangement                     | 14        |
| 2.3      | INSTALLING THE Mx-4200 & 4400 ENCLOSURES                  | 14        |
| 2.3.1    | Opening the Enclosure Cover                               | 14        |
| 2.3.2    | Removing the Chassis                                      | 14        |
| 2.3.3    | Mounting the Enclosure                                    | 15        |
| 2.3.4    | Remounting the Chassis                                    | 15        |
| 2.3.5    | Recommended Cable Routing Arrangement                     | 15        |
| 2.4      | INSTALLING THE Mx-4400/LE AND Mx-4800 ENCLOSURES          | 16        |
| 2.4.1    | Opening the Enclosure Cover                               | 16        |
| 2.4.2    | Removing the Chassis                                      | 16        |
| 2.4.3    | Mounting the Enclosure                                    | 16        |
| 2.4.4    | Remounting the Chassis                                    | 17        |
| 2.4.5    | Recommended Cable Routing Arrangement                     | 17        |
| 2.5      | LOOP DRIVER INSTALLATION                                  | 18        |
| 2.5.1    | Fitting the cards in the Mx4200, Mx-4400 & Mx-4800        | 18        |
| 2.5.2    | Removing a Loop Driver Card                               | 18        |
| 2.6      | LOCAL PERIPHERAL MODULES                                  | 19        |
| 2.6.1    | Peripheral Bus Interface Adaptor                          | 19        |
| 2.6.2    | Routing Interface Card                                    | 19        |
| 2.7      | WIRING INSTALLATION                                       | 20        |
| 2.7.1    | AC Mains Wiring   | 20        |
| 2.7.1.1  | Cable Gland   | 21        |
| 2.7.2    | Battery Installation                                      | 21        |
| 2.7.2.1  | Mx-4100   | 22        |
| 2.7.2.2  | Mx-4200 & Mx-4400   | 22        |
| 2.7.2.3  | Mx-4400/LE & Mx-4800                                      | 23        |
| 2.7.2.4  | Battery Temperature Monitoring                            | 23        |
| 2.7.3    | Detector Loop Installation                                | 24        |
| 2.7.4    | Sounder Circuits  | 25        |
| 2.7.5    | Relay Circuits  | 25        |
| 2.7.6    | Open Collector Outputs                                    | 26        |
| 2.7.7    | Auxiliary Supply Output                                   | 26        |
| 2.7.8    | Switch Inputs   | 26        |
| 2.7.9    | RS232 Interface   | 27        |
| 2.7.10   | Isolated Bus Interface                                    | 27        |
| 2.7.11   | Routing Interface   | 27        |
| <b>3</b> | <b>PROGRAMMING</b>  | <b>28</b> |

|            |  |           |
|------------|--|-----------|
| <b>3.1</b> | <b>INTRODUCTION</b>                          | <b>28</b> |
| 3.1.1      | Access Levels                                | 28        |
| 3.1.2      | Memory Lock                                  | 28        |
| 3.1.3      | Navigating through menus                     | 28        |
| 3.1.4      | Changing Text Descriptions                   | 29        |
| 3.1.5      | Numeric data entry                           | 30        |
| <b>3.2</b> | <b>RECOMMENDED PROGRAMMING PROCEDURE</b>     | <b>30</b> |
| <b>3.3</b> | <b>LEVEL 3 MENU FUNCTIONS</b>                | <b>30</b> |
| 3.3.1      | Loops  | 31        |
| 3.3.2      | Loops – View/Edit                            | 31        |
| 3.3.2.1    | State  | 31        |
| 3.3.2.2    | Type   | 31        |
| 3.3.2.3    | Value  | 32        |
| 3.3.2.4    | Zone   | 32        |
| 3.3.2.5    | Device Text                                  | 32        |
| 3.3.2.6    | Action                                       | 32        |
| 3.3.2.7    | Sensitivity                                  | 32        |
| 3.3.2.8    | O/P Group                                    | 34        |
| 3.3.2.9    | Additional Info                              | 35        |
| 3.3.2.10   | Device Testing                               | 35        |
| 3.3.3      | Loops – Auto Learn                           | 36        |
| 3.3.3.1    | Normal Procedure / Initial learn             | 36        |
| 3.3.3.2    | Procedure if the Panel finds Devices Missing | 36        |
| 3.3.3.3    | Procedure if the Panel finds Devices Added   | 37        |
| 3.3.3.4    | Procedure if the Panel finds Devices Changed | 37        |
| 3.3.4      | Loop – Calibrate                             | 37        |
| 3.3.5      | Loop – Driver                                | 37        |
| 3.3.6      | Zones  | 38        |
| 3.3.7      | Exit   | 38        |
| 3.3.8      | Outputs                                      | 38        |
| 3.3.8.1    | Default Output Settings                      | 39        |
| 3.3.8.2    | Cause  | 39        |
| 3.3.8.3    | Style  | 40        |
| 3.3.8.4    | Copying Output Settings to Multiple Zones    | 41        |
| 3.3.9      | Investigation Delays                         | 41        |
| 3.3.9.1    | Overriding Delays at Level 1                 | 41        |
| 3.3.10     | Time and Date                                | 41        |
|            | View Options                                 | 42        |
| 3.3.11     | Passwords                                    | 42        |
| 3.3.12     | Panel  | 42        |
| 3.3.12.1   | AC Fail Delay                                | 42        |
| 3.3.13     | PC Config                                    | 43        |
| 3.3.14     | Setup  | 43        |
| 3.3.14.1   | Network                                      | 43        |
| 3.3.14.2   | Panel Zone                                   | 43        |
| 3.3.14.3   | Service Number                               | 43        |
| 3.3.14.4   | Service Due Date                             | 44        |
| 3.3.14.5   | Trace Logging Mode                           | 44        |
| 3.3.14.6   | Detector Blinking                            | 44        |
| 3.3.14.7   | Earth Fault Notification                     | 45        |
| 3.3.14.8   | Routing Interface                            | 45        |
| 3.3.14.9   | Resound Alarms                               | 45        |
| 3.3.14.10  | Program ID                                   | 45        |
| 3.3.14.11  | Config Data                                  | 46        |
| <b>4</b>   | <b>SERVICE AND MAINTENANCE</b>               | <b>47</b> |
| <b>4.1</b> | <b>MAINTENANCE SCHEDULE</b>                  | <b>47</b> |
| 4.1.1      | Daily Actions                                | 47        |
| 4.1.2      | Monthly Actions                              | 47        |
| 4.1.3      | Quarterly Actions                            | 47        |
| 4.1.4      | Annual Actions                               | 47        |
| <b>4.2</b> | <b>REPLACEMENT OF COMPONENTS</b>             | <b>48</b> |
| 4.2.1      | Batteries                                    | 48        |
| 4.2.1.1    | Standby Batteries                            | 48        |
| 4.2.1.2    | Lithium Battery                              | 49        |

|             |  |           |
|-------------|--|-----------|
| 4.2.2       | Liquid Crystal Display   | 49        |
| <b>5</b>    | <b>APPENDICES</b>  | <b>50</b> |
| <b>5.1</b>  | <b>APPENDIX 1 – FORGOTTEN LEVEL 3 PASSWORD</b>                   | <b>50</b> |
| <b>5.2</b>  | <b>APPENDIX 2 – RECOMMENDED FIRE RATED CABLES</b>                | <b>51</b> |
| 5.2.1       | Detector Loop Lengths  | 51        |
| 5.2.2       | Sounder Circuit Lengths  | 52        |
| 5.2.3       | Fire / Fault Routing Circuit Lengths                             | 52        |
| 5.2.4       | Network Cables   | 52        |
| <b>5.3</b>  | <b>APPENDIX 3 – BATTERY STANDBY CALCULATION CHART</b>            | <b>53</b> |
| 5.3.1       | Mx-4100  | 53        |
| 5.3.2       | Mx-4200 / Mx-4400 / Mx-4800                                      | 54        |
| <b>5.4</b>  | <b>APPENDIX 4 – CAUSE AND EFFECT PROGRAMMING EXAMPLE</b>         | <b>55</b> |
| 5.4.1       | Introduction   | 55        |
| 5.4.2       | Output Groups  | 55        |
| 5.4.3       | Styles   | 55        |
| 5.4.4       | Output Group Programming   | 56        |
| <b>5.5</b>  | <b>APPENDIX 5 – APOLLO INFORMATION</b>                           | <b>57</b> |
| 5.5.1       | View Drift   | 57        |
| 5.5.2       | Rapid Compensation   | 57        |
| 5.5.3       | View EEPROM  | 58        |
| 5.5.4       | Loop Isolators   | 58        |
| 5.5.5       | Sounder Group Addressing   | 58        |
| <b>5.6</b>  | <b>APPENDIX 6 – HOCHIKI ESP INFORMATION</b>                      | <b>59</b> |
| 5.6.1       | Unprocessed Analogue information                                 | 59        |
| 5.6.2       | CHQ-BS / CHQ-WS Sounders   | 59        |
| <b>5.7</b>  | <b>APPENDIX 7 – Mx4000 SERIES LOOP OUTPUT DRIVE CAPABILITY</b>   | <b>60</b> |
| 5.7.1       | Hochiki  | 60        |
| 5.7.2       | Apollo   | 60        |
| <b>5.8</b>  | <b>APPENDIX 8 – OTHER USEFUL DOCUMENTS</b>                       | <b>61</b> |
| <b>5.9</b>  | <b>APPENDIX 9 – Mx-4800 / NETWORK DESIGN PRINCIPLES</b>          | <b>62</b> |
| 5.9.1       | Mandatory Functions  | 62        |
| 5.9.2       | Network Wiring   | 62        |
| <b>5.10</b> | <b>APPENDIX 10 – Mx SERIES PRODUCT CAPABILITIES / MAX LIMITS</b> | <b>63</b> |

# 1 Introduction

## 1.1 Standards

Advanced Electronics Ltd declares that the products identified below conform to the essential requirements specified in the Construction Products Regulation 305/2011:

|  |                   |
|--|-------------------|
|   | <b>D.o.P 4000</b> |
| EN54-2: 1997 +A1:2006<br>Control and indicating equipment for fire detection and fire alarm systems for buildings  |                   |
| Provided options: <ul style="list-style-type: none"><li>- Outputs to Fire Alarm Devices</li><li>- Output to Fire Routing Equipment</li><li>- Output to Fault Routing Equipment</li><li>- Investigation Delays to Outputs</li><li>- Dependency on more than one alarm signal</li><li>- Fault Signals from Points</li><li>- Disablement of Points</li><li>- Alarm Counter</li><li>- Test Condition</li><li>- Standardised Input / Output</li></ul> |                   |
| EN54-4: 1997 +A1:2002 +A2:2006<br>Power supply equipment for fire detection and fire alarm systems for buildings   |                   |
| <b>Mx-4100, Mx-4100/L, Mx-4200, Mx-4200/D, Mx-4400, Mx-4400/D, Mx-4400/LE and Mx-4800</b>  |                   |

In addition, the products comply with the following:

Low Voltage Directive 2014/35/EU

EN62368-1:2014 +A11:2017

Audio/video, information and communication technology equipment.  
Safety requirements.

Electromagnetic Compatibility Directive 2014/30/EU

EN61000-6-3 2007 +A1:2011

Emissions, Class B

EN50130-4: 1995 +A1:1998 +A2: 2003

Immunity, Product Family Standard

## 1.2 Cautions and Warnings



**BEFORE INSTALLATION – Refer To the Ratings shown on the label inside the product and to the ‘Specifications Chart’ in this document.**

**Please read this manual carefully. If you are unclear on any point DO NOT proceed. Contact the manufacturer or supplier for clarification and guidance.**



**Only Trained service personnel should undertake the Installation, Programming and Maintenance of this equipment.**



**This product has been designed to comply with the requirements of the Low Voltage Safety and the EMC Directives. Failure to follow the installation instructions may compromise its adherence to these standards.**



**This equipment is constructed with static sensitive components. Observe anti-static precautions at all times when handling printed circuit boards. Wear an anti-static earth strap connected to panel enclosure earth point. Before installing or removing any printed circuit boards remove all sources of power (mains and battery).**

## 1.3 Description

This manual covers the installation, programming and commissioning of the *Mx-4100*, *Mx-4200*, *Mx-4400* and *Mx-4800* Fire Alarm Control Panels. Refer to the User Manual (Document No. 680-015) for details of how to operate the panel.

The *Mx-4100* is a Single Loop, Analogue Addressable Fire Alarm Control Panel.

The *Mx-4200* is a Multiple Loop, Analogue Addressable Fire Alarm Control Panel with provision for up to two loops.

The *Mx-4400* is a Multiple Loop, Analogue Addressable Fire Alarm Control Panel with provision for up to four loops.

The *Mx-4800* is a Multiple Loop, Analogue Addressable Fire Alarm Control Panel with provision for up to eight loops.

All models are designed for use with the Apollo Discovery, Explorer, XP95 and Series 90 and Hochiki ESP fire detection devices.

**Install the panel, detection loops, sounder circuits, etc. in accordance with the instructions in Section 2 and then program the operation in accordance with the instructions detailed in Section 3.**

## 1.4 EN54 Functions

|   |   |
|---|---|
|  | <p>This Fire Alarm Control Panel is compliant with the requirements of EN54 parts 2 and 4 (1997).</p> <p>In addition to the basic requirements, the following optional functions are provided and these comply with the requirements of EN54.</p> |
|---|---|

|  | C.I.E Optional Functions |                                   | EN54-2 Clause |
|---|--------------------------|-----------------------------------|---------------|
|   | Indication               | Outputs to Fire Alarm Devices     | 7.8           |
|   | Outputs                  | Outputs to Fire Routing Equipment | 7.9           |
|   | Controls                 | Investigation Delays to Outputs   | 7.11          |
|   |                          | Co-incident Detection             | 7.12          |
|   |                          | Alarm Counter                     | 7.13          |
|   |                          | Fault Signals from Points         | 8.3           |
|   |                          | Output to Fault Routing Equipment | 8.9           |
|   |                          | Disabling of Points               | 9.5           |
|   |                          | Test Condition                    | 10            |
| Standardised I/O  |                          | 11                                |               |

|  | P.S.E Functions                        |  | EN54-4 Clause |
|--|--|--|---------------|
|  | Operation from a main power supply     |  | 5.1           |
|  | Operation from a standby battery       |  | 5.2           |
|  | Monitor and Charge the Standby Battery |  | 5.3           |
|  | Recognise and Notify Supply Faults     |  | 5.4           |

|  | This Fire Alarm Control Panel also supports additional functions that are not covered by EN54. These are as follows: |                       |
|---|--|-----------------------|
|   | Additional Function  | Refer to Paragraphs   |
|   | Auxiliary Power Supply Output  | <a href="#">2.7.7</a> |
|   | Auxiliary Relay Outputs  | <a href="#">2.7.5</a> |
|   | Programmable Cause / Effect on Outputs (Phased Evacuation)   | <a href="#">5.4</a>   |
| Printer Option  | User Manual  |                       |

## 1.5 EN54 Optional Features with Requirements

In addition to the mandatory requirements of EN54 Part 2, the Control and Indicating Equipment (C.I.E) supports the following optional features with requirements: -



Section 7.8

### Outputs to Fire Alarm Devices.

The C.I.E has provision for connection to Fire Alarm Devices. It is possible to Silence and Resound the alarms at Level 2. Refer to the User Manual for further information. Refer to Sections 3.3.8 and 3.3.9 for information on output programming.



Section 7.9

### Outputs to Fire Routing Equipment.

The C.I.E has provision to signal the fire condition to a remote receiving station such as the fire brigade office. Requires installation of a routing interface card. Refer to Sections 2.6.2, 2.7.11, 3.3.8, 3.3.9 and 3.3.14.8 for further information



Section 7.11

### Delays to Outputs.

The C.I.E has provision for Output and Investigation Delays. Refer to Sections 3.3.8 & 3.3.9 for further information



Section 7.12

### Coincidence Detection.

The C.I.E has provision for Coincidence Detection. Refer to Section 3.3.8 for further information. Types B and C are supported.



Section 7.13

### Alarm Counter.

The C.I.E has provision record the number of times that the fire alarm condition is entered. Refer to the User Manual for further information.



Section 8.3

### Fault Signals from Points.

The C.I.E is able to receive and process fault signals from points. These are indicated on a per zone basis. Refer to the User Manual for further information.



Section 8.9

### Outputs to Fault Routing Equipment.

The C.I.E has provision to signal the fault condition to a remote receiving station such as the service centre office. Requires installation of a routing interface card. Refer to Sections 2.6.2, 2.7.11, 3.3.8, 3.3.9 and 3.3.14.8 for further information



Section 9.5

### Disablement of Points.

The C.I.E has provision for enabling and disabling signals from points. Refer to the User Manual for further information.



#### **Test Condition.**

The C.I.E has provision for testing the installation on a per zone basis. Refer to the User Manual for further information.



#### **Standardised Input/Output interface.**

Standardised I/O interfaces are supported over the *Ad-Net* Network.

## **1.6 Installation Approvals**

### **1.6.1 Fire System Installations**

The panel must be installed and configured for operation in accordance with these instructions and the applicable code of practice or national standard regulations for fire systems installation (for example BS5839-1:2013) appropriate to the country and location of the installation.

### **1.6.2 Wiring Regulations**

The panel and system must be installed in accordance with these instructions and the applicable wiring codes and regulations (for example BS7671) appropriate to the country and location of the installation.



### 2.1.3 Mx-4400/LE

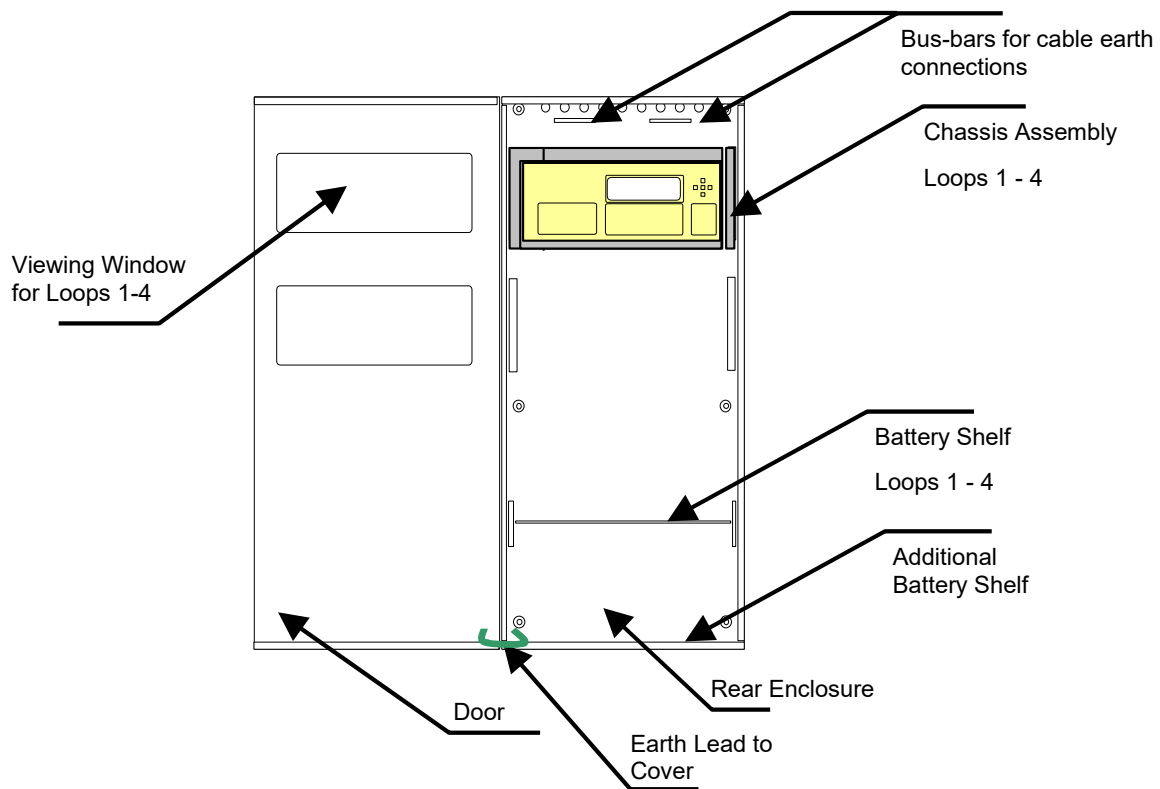

### 2.1.4 Mx-4800

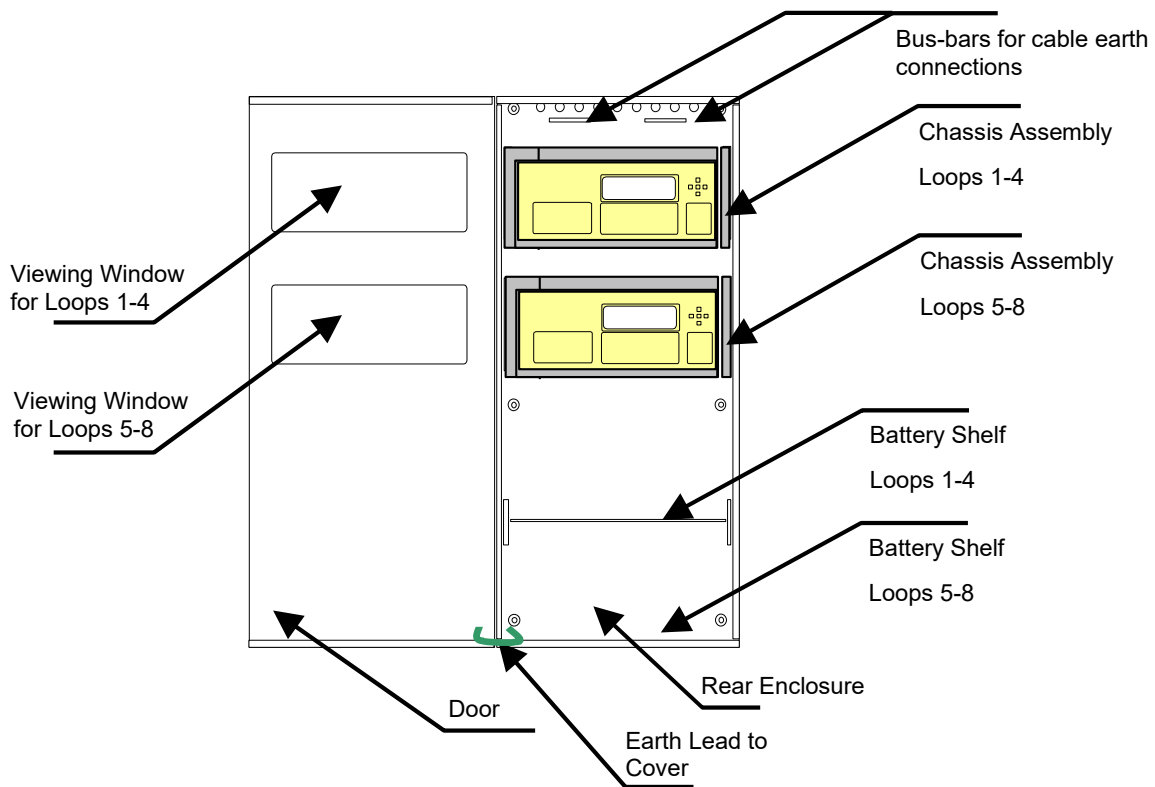

## 2.2 Installing the Mx-4100 Enclosure



The panel can weigh in excess of 15kg when the batteries are installed. Use the appropriate fixing hardware to secure the panel to the wall. Observe recommended lifting practices to guard against spinal injury.

### 2.2.1 Removing and Replacing the Enclosure Cover of the Mx-4100

The enclosure cover is fixed in place with two tamper resistant hexagon key screws. These require the use of a 2.5mm Allen Key. The enclosure cover must be connected to earth. When replacing the cover, always ensure that the earth lead spade terminal is securely seated onto the blade terminal in the back box.

### 2.2.2 Removing the Chassis

It is recommended that the chassis be removed before fitting the panel to the wall. To remove the chassis:

Disconnect the earth cable connecting the chassis to the spade terminal on the rear enclosure.

Remove the two screws holding the chassis to the back box. Keep these items in a safe place for later re-use.

Unplug the 3-way connector feeding the power supply to the Base Card. Carefully remove the chassis from the rear enclosure and place in a safe place to prevent accidental damage.



Do not lift the chassis by holding onto any of the printed circuit cards. Hold the chassis by the metal plate only.

### 2.2.3 Mounting the Enclosure

Firstly, remove the required knockouts for the installation wiring. There are sufficient knockouts on the top of the enclosure for all installation wiring. In addition, there are knockouts at the top of the back wall, if required, for rear entry cabling.

The enclosure is provided with four fixing points.

The diagram opposite shows the positions of the four holes. Use all four positions to ensure the panel is held securely to the wall.

Drill the required holes in the supporting wall using a drill bit diameter 7.0 mm and plug with a suitable 40mm long expansion plug. Affix the panel to the wall with M5 screws (length 40mm) or No.10 screws (length 1½").

Ensure that there is sufficient space to allow the cover to be removed / replaced when the panel is mounted.

Finally, use a brush to remove any dust or swarf from inside the enclosure.

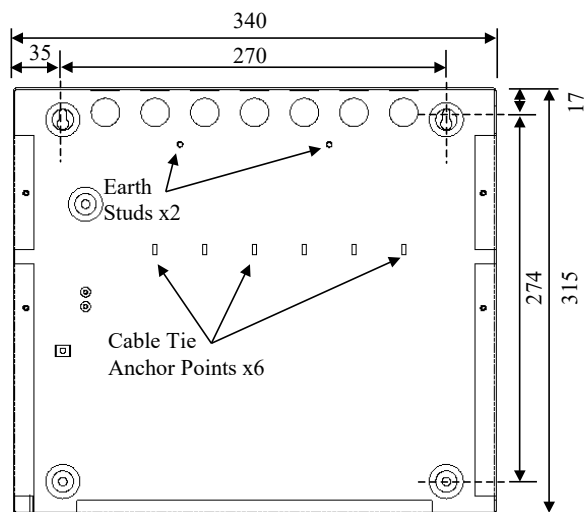

Enclosure Size and Fixing Point Dimensions

### 2.2.4 Remounting the Chassis

Carefully replace the chassis and fix into place using the two screws.

Reconnect the chassis earth cable to the spade terminal in the rear of the enclosure and then reconnect the supply lead from the transformer to the Base Card.

## 2.2.5 Recommended Cable Routing Arrangement

It is recommended that the routing arrangement shown in the diagram opposite be employed.

Segregate the low voltage wiring (Loop Circuit, Sounder Circuits and AUX Supply) from the AC Mains Wiring.

Segregate any wiring connected to the relay contacts.

Eyelets are provided in the rear of the back box to enable the cables to be securely fastened using tie-wraps.

Refer to [Appendix 2 – Recommended Fire Rated Cables](#) for further information on cable types to be used.

Refer to specific sections on how to install AC Mains input and loop, sounder, relay and AUX outputs circuits.

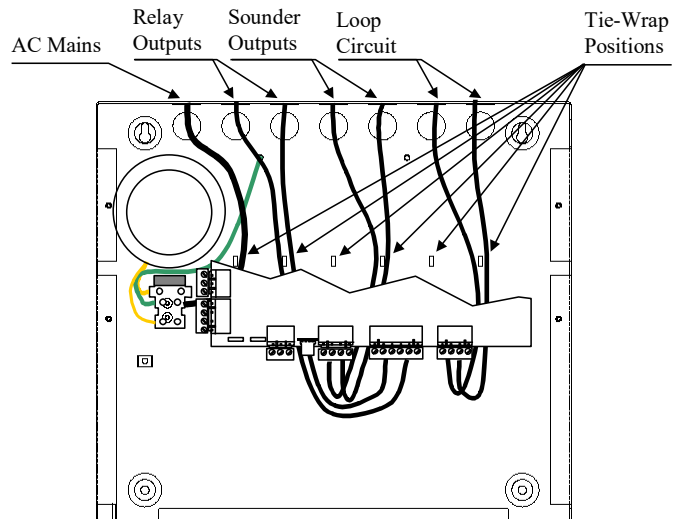

Internal arrangement showing recommended routing of cables.

## 2.3 Installing the Mx-4200 & 4400 Enclosures



The panel can weigh in excess of 20kg when the batteries are installed. Use the appropriate fixing hardware necessary to secure the panel to the wall. Observe recommended lifting practices to guard against spinal injury.

### 2.3.1 Opening the Enclosure Cover

The Mx-4200 & Mx-4400 are provided with a key-lock assembly for securing the hinged door to the back box. Insert and turn the key to open the enclosure.

### 2.3.2 Removing the Chassis

It is recommended that the chassis be removed before fitting the panel to the wall. To remove the chassis:

Refer to the diagram opposite.

Disconnect the earth cable connecting the chassis to the spade terminal on the rear enclosure.

Remove the bottom two screws holding the chassis to the back box. Keep these items in a safe place for later re-use.

Loosen the top two screws holding the chassis to the back box via the keyhole slots. The chassis assembly can now be removed.

Carefully remove the chassis from the rear enclosure and place in a safe place to prevent accidental damage.

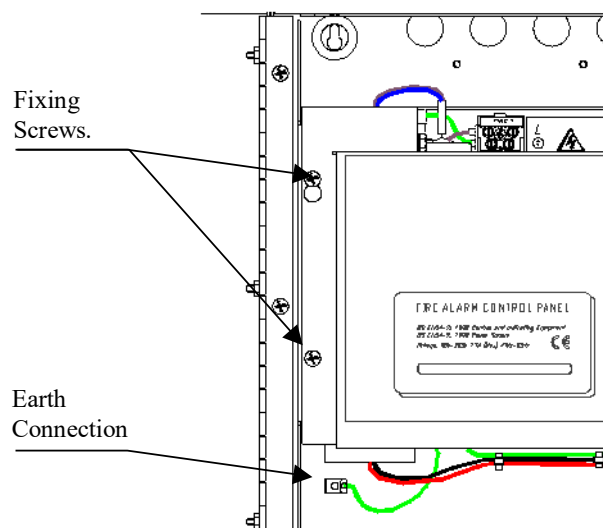

Do not lift the chassis by holding onto any of the printed circuit cards. Hold the chassis by the metal plate only.

### 2.3.3 Mounting the Enclosure

Firstly, remove the required knockouts for the installation wiring. There are sufficient knockouts on the top of the enclosure for all installation wiring. In addition, there are knockouts at the top of the back wall, if required, for rear entry cabling.

The diagram opposite shows the positions of the four holes. Use all four positions to ensure the panel is held securely to the wall.

Drill the required holes in the supporting wall using a drill bit diameter 7.0 mm and plug with a suitable 40mm long expansion plug. Affix the panel to the wall with M5 screws (length 40mm) or No.10 screws (length 1½").

Ensure that there is sufficient space to allow the door to be opened when the panel is mounted.

Finally, use a brush to remove any dust or swarf from inside the enclosure.

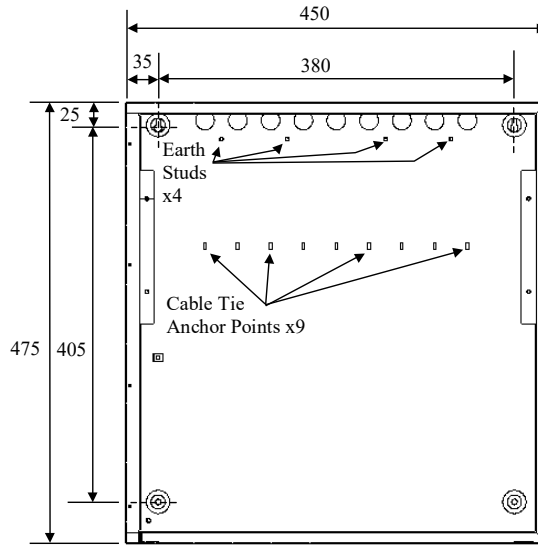

Enclosure Size and Fixing Point Dimensions

### 2.3.4 Remounting the Chassis

Carefully replace the chassis and locate onto the upper two screws. Replace the bottom two screws and tighten all four screws to hold the chassis securely to the back box.



**Reconnect the chassis earth cable to the spade terminal in the rear of the enclosure.**

### 2.3.5 Recommended Cable Routing Arrangement

It is recommended that the routing arrangement shown in the diagram opposite be employed.

Segregate the low voltage wiring (Loop Circuit, Sounder Circuits, RS485 and AUX Supply) from the AC Mains Wiring and any wiring connected to the relay contacts.

Eyelets are provided in the rear of the back box to enable the cables to be securely fastened using tie-wraps.

Sounders and AUX wiring should be routed behind the chassis assembly and tie-wrapped to the back box.

Cable screens / shields should be connected to the back box using the threaded studs provided near the knockout holes. Multi-way Bus bars are available separately for mounting on the threaded studs.

Refer to [Appendix 2 – Recommended Fire Rated Cables](#) for further information on cable types to be used.

Refer to specific sections on how to install AC Mains input and loop, sounder, relay and AUX outputs circuits.

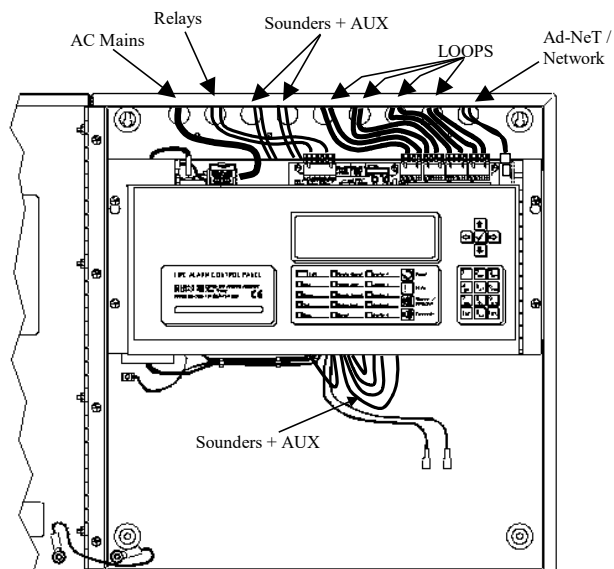

Internal arrangement showing recommended routing of cables.

## 2.4 Installing the Mx-4400/LE and Mx-4800 Enclosures



The panel can weigh in excess of 80kg when the batteries are installed. Use the appropriate fixing hardware necessary to secure the panel to the wall. Observe recommended lifting practices to guard against spinal injury.

### 2.4.1 Opening the Enclosure Cover

The Mx-4400/LE and Mx-4800 are provided with two key-lock assemblies for securing the hinged door to the back box. Insert and turn both keys to open the enclosure.

### 2.4.2 Removing the Chassis

It is recommended that the chassis assemblies be removed before fitting the panel to the wall. To remove the chassis:

Refer to the diagram opposite.

Disconnect the earth cable connecting the chassis to the spade terminal on the rear enclosure.

Remove the bottom two screws holding the chassis to the back box. Keep these items in a safe place for later re-use.

Loosen the top two screws holding the chassis to the back box via the keyhole slots. The chassis assembly can now be removed.

Carefully remove the chassis from the rear enclosure and place in a safe place to prevent accidental damage.

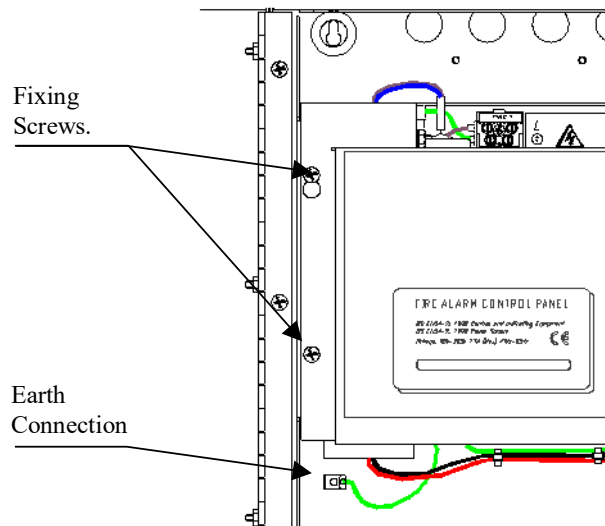

### 2.4.3 Mounting the Enclosure

Firstly, remove the required knockouts for the installation wiring. There are sufficient knockouts on the top of the enclosure for all installation wiring. In addition, there are knockouts at the top of the back wall, if required, for rear entry cabling.

The diagram opposite shows the positions of the six holes. Use all six positions to ensure the panel is held securely to the wall.

Drill the required holes in the supporting wall using a drill bit diameter 10.0 mm and plug with a suitable 50mm (minimum) long metal expansion plug. Affix the panel to the wall with M6 screws (length 50mm minimum).

Ensure that there is sufficient space to allow the door to be opened when the panel is mounted.

Finally, use a brush to remove any dust or swarf from inside the enclosure.

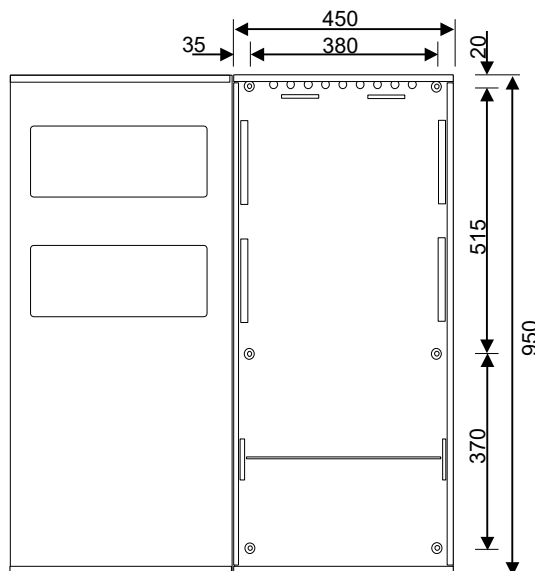

Enclosure Size and Fixing Point Dimensions

## 2.4.4 Remounting the Chassis

Carefully replace the chassis and locate onto the upper two screws. Replace the bottom two screws and tighten all four screws to hold the chassis securely to the back box.



Reconnect the chassis earth cable to the spade terminal in the rear of the enclosure.

## 2.4.5 Recommended Cable Routing Arrangement

It is recommended that the routing arrangement shown in the diagram opposite be employed.

Segregate the low voltage wiring (Loop Circuit, Sounder Circuits, RS485 and AUX Supply) from the AC Mains Wiring.

Segregate any wiring connected to the relay contacts.

Eyelets are provided in the rear of the back box to enable the cables to be securely fastened using tie-wraps.

Sounders and AUX wiring should be routed behind the chassis assembly and tie-wrapped to the back box.

Cable screens / shields should be connected to the back box using Bus Bars provided near the knockout holes.

Refer to [Appendix 2 – Recommended Fire Rated Cables](#) for further information on cable types to be used.

Refer to specific sections on how to install AC Mains input and loop, sounder, relay and AUX outputs circuits.

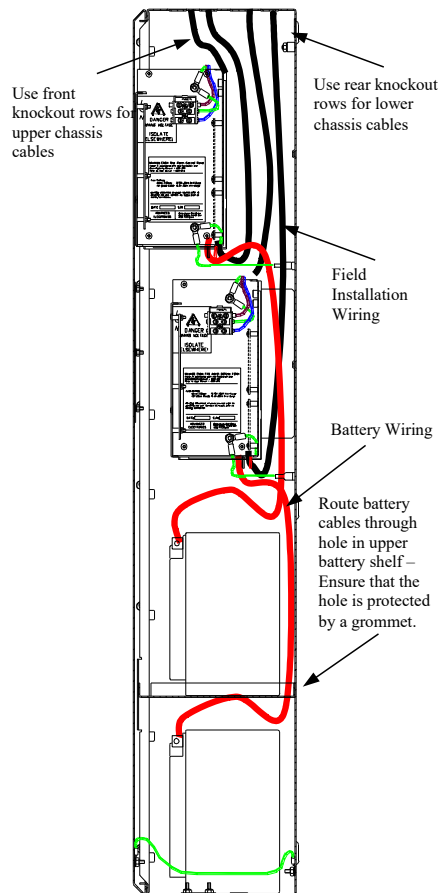

Internal arrangement showing recommended routing of cables.

## 2.5 Loop Driver Installation

The Mx-4100 has one in-built loop driver, for connection of detectors, call points and other signalling devices.

### 2.5.1 Fitting the cards in the Mx4200, Mx-4400 & Mx-4800

To extend the number of detector loops or to replace an existing loop driver card follow the procedure described below.

An example of the loop driver is shown opposite. This is provided with a plastic grip handle on the top edge to ease removal of the card from the Base Card.



**Isolate ALL sources of power before installing or removing printed circuit boards.**



**Observe anti-static precautions at all times when handling printed circuit boards.**

Open the enclosure and then open the display plate (it is hinged on the right hand side and there is a magnetic catch strip on the left-hand side) to gain access to the Base Card.

A section of the Base Card identifying the locations for each loop driver is shown in the picture opposite

To install a loop driver, remove the retaining strap, then gently guide the loop driver printed circuit card into the guide slots of the machined end blocks and then push into place onto the connector on the Base Card.

Ensure that the pins of the connectors are correctly aligned. The loop driver should be inserted with the component side of the board placed on the left-hand side. Replace the retaining strap.

The Base Card can accept up to four loop driver cards – it does not matter which positions are used. Ensure that the detector loop wiring is made to the terminal block positions appropriate to the loop driver cards actually installed.

Close the chassis display plate and then close up the enclosure.

### 2.5.2 Removing a Loop Driver Card

To remove a loop driver, remove all power and follow the procedure above but:

Take a firm hold of the lever located on top of the loop driver card. Gradually and carefully pull the loop driver away from the base card and guide it out of the slots in the machined end blocks.

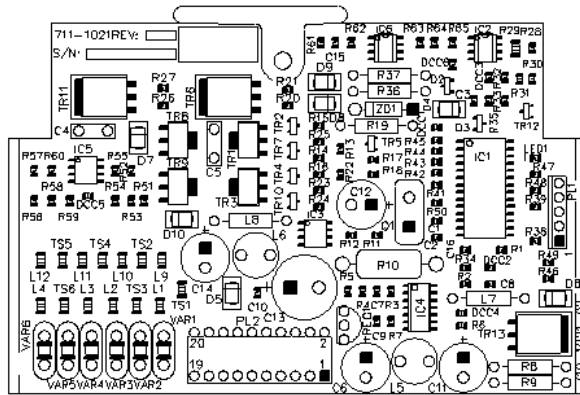

Loop Driver – Component Side View

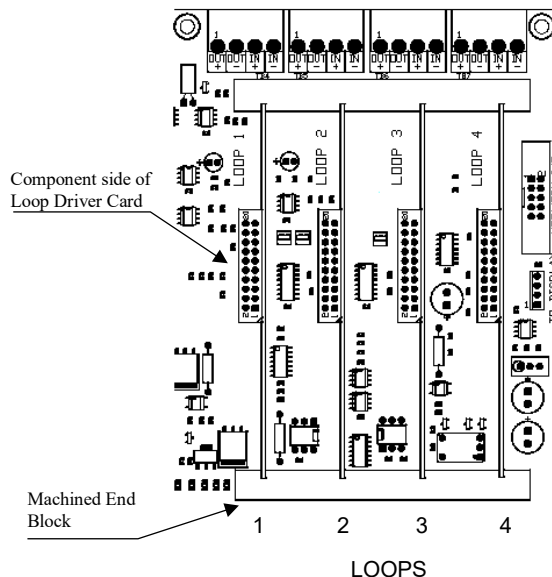

NB: The Mx-2000 only has positions 1 & 2 available.

## 2.6 Local Peripheral Modules

The Mx-4200, Mx-4400 and Mx-4800 panels provide provision for installation / use of local peripheral cards to provide additional functions. The peripherals are connected via an isolated bus interface.

The panel supports the Mxp-032 General Routing Interface and up to sixteen Mxp-034 4-Way Programmable Sounder Modules and up to sixteen Mxp-035 4-Way Programmable Relay Modules <sup>3</sup>.

### 2.6.1 Peripheral Bus Interface Adaptor

To use the local peripheral bus Interface requires the installation of an Adaptor Card – Mxp-031.

Refer to the diagram opposite for location.

Secure the board in place (to prevent problems due to vibration) using the clamping plate to hold the card securely to the lower loop driver location block.

A tab on the adaptor card fits into a slot in the clamp.

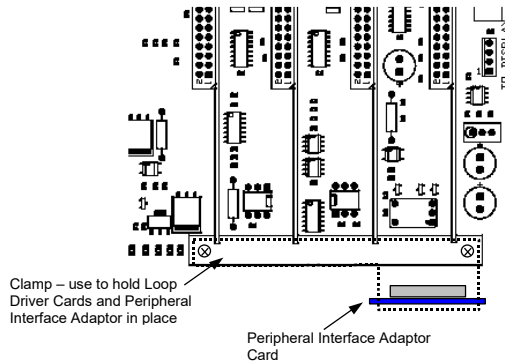

*Mounting Position for the Interface Adaptor*

### 2.6.2 Routing Interface Card



#### Outputs to Routing Equipment – Clauses 7.9 and 8.9.

The Routing Interface Card (Mxp-032) provides monitored outputs for connection to Fire Routing Equipment (Item E) and Fault Routing Equipment (Item J) in accordance with EN54-2.

The card is fitted to the chassis using 4x M3 screws. Refer to the diagram opposite.

Cables are provided for connection of a local 24V DC supply and communications connections.

Connect the DC Supply from the AUX output to the connections on TB4 observing polarities.

Connect the communications cable between TB3 on the Base Card and TB4 on the routing interface so that 'A' is connected to 'A' and 'B' to 'B'.

For further information, refer to Document 680-081.

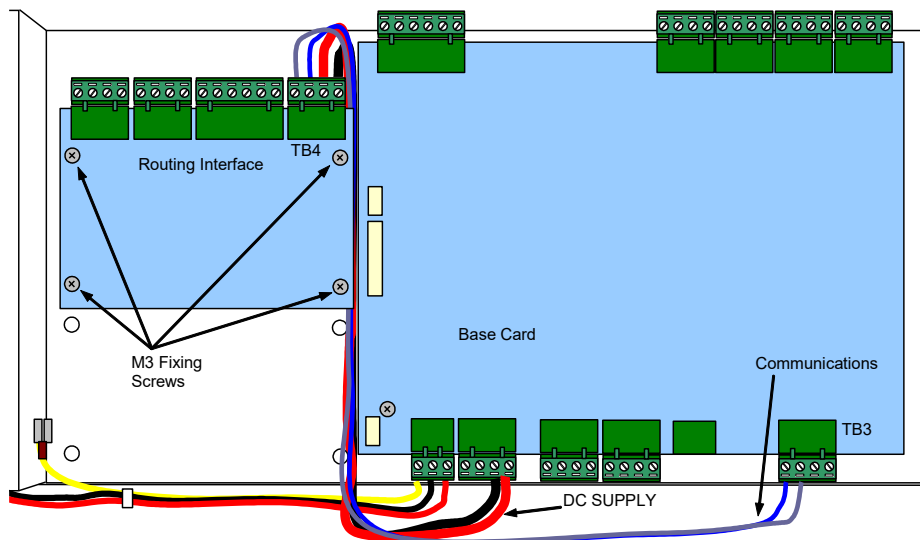

*Mounting Position for the Routing Interface Card*

<sup>3</sup> The Mxp-034 and Mxp-035 modules must be configured using the PC CONFIG TOOL. A maximum of 32 modules (of any type) can be connected only. Refer to the installation guides provided with each module for further details.

## 2.7 Wiring Installation

All electrical wiring installation work should be carried out in accordance with the code of practice or applicable national standards appropriate to the country of installation.

To maintain electrical integrity of the SELV wiring on the input, output, loop and communications lines all SELV wiring should be segregated from the LV mains wiring and be wired using cable with insulation suitable for the application.

To minimise the effects of EMC interference all data wiring circuits should be wired with a twisted pair of conductors with a cross sectional area suitable for the loading conditions.

In areas where cabling may come into contact with high frequency interference, such as portable radio transceivers etc. the data wiring cable should be of a twisted pair construction within an overall screen. Care should be taken to correctly terminate this screen, refer to the appropriate sections of this manual for further information for each circuit type.

NB: Minimum / Maximum cable size for all external connections is limited to 0.5mm<sup>2</sup> / 2.5mm<sup>2</sup> (22-14AWG).

### 2.7.1 AC Mains Wiring

Route the high voltage mains AC wiring into the enclosure at the upper left corner only. Keep the AC wiring away from the circuit boards and all other wiring.



The panels must be connected to the supply earth through the power cable.

The mains input connector is shown in the diagram opposite. Note the positions of the earth, neutral and live terminal connections. These are clearly marked on the label next to the connector. The connector block contains an integral fuse holder.

Secure the mains input wiring by tie wrap as close to the terminal block as possible.

The fuses are rated as follows:

T 1.0A H 250V (for Mx-4100)

T 3.15A H 250V (for Mx-4200, Mx-4400 & Mx-4800)

Replace with correct rating and specification only.

Connect the Control Panel to the mains supply via a readily accessible disconnect-device (Isolation Switch) and suitable earth fault protection incorporated in the building installation wiring. The Mains cable should be 0.75mm<sup>2</sup> cable rated at 250V and fused via a 5A anti-surge fuse.

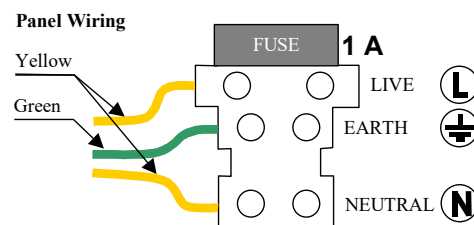

AC Mains terminations – Mx-4100.

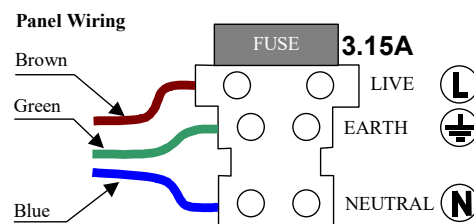

AC Mains terminations – Mx-4200 & Mx-4400

The Mx-4800 employs two terminal blocks for the AC Mains connections (one on each chassis assembly) as per the Mx-4400.

### 2.7.1.1 Cable Gland



The cable gland and any cord clamp bushings used in routing the Mains cable through the 20mm knockout must have a minimum flame-retardant rating of UL94 V-1.

### 2.7.2 Battery Installation

The panel requires two 12V batteries for standby operation.

The battery leads are connected onto the base card via a two-part plug and socket, as shown in the diagram opposite.

Refer to the Specifications for minimum and maximum battery sizes allowed.

Base Card Terminations

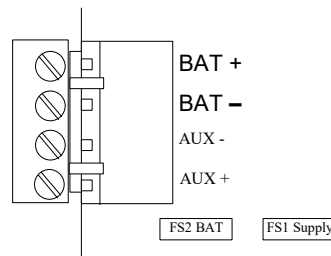

Mx-4100

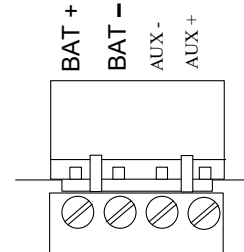

Mx-4200, Mx4400 & Mx4800

Place the batteries in the bottom of the enclosure and connect the 'Red' lead to the positive (+) terminal of battery #1 and the 'Black' lead to the negative (-) terminal of battery #2. Connect the negative of battery #1 to the positive of battery #2 using the supplied link cable.

Ensure that the battery terminals do not short out against any part of the enclosure, circuit board or chassis plate.

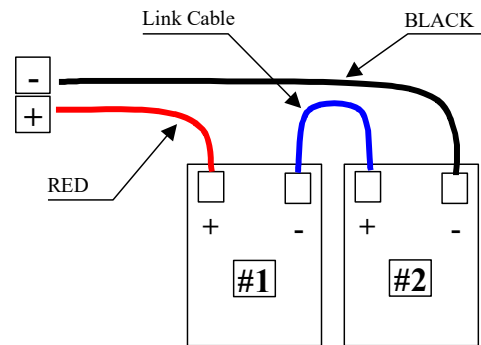

**Do not make the final battery connections until the installation wiring is completed and the system is to be powered up.**

**Always connect the AC Mains input before connecting the battery.**

New batteries require 'top-charging' before installation. Refer to Section 4.2.1.1 for a list of recommended batteries.

### 2.7.2.1 Mx-4100

The diagram opposite shows the recommended location and orientation for the 7AH batteries within the panel.

For battery sizes greater than 7AH, the batteries must be installed in a separate enclosure suitable for fire protection use with wiring connected to the panel through rigid conduit.

#### Replacement Fuses

FS1 T5A 125V Anti-Surge

FS2 T5A 125V Anti-Surge

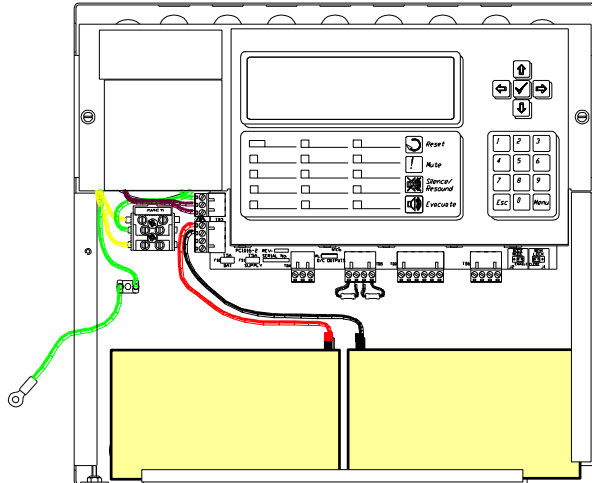

### 2.7.2.2 Mx-4200 & Mx-4400

The diagrams opposite show the recommended location and orientation for the 12AH and 17AH batteries within the panel.

For battery sizes greater than 17AH, use the Mx-4400/D for batteries up to 38AH and use the Mx-4400/LE large enclosure variant for up to 48AH.

For battery sizes greater than 12AH, it will be necessary to remove the spade terminals fixed to the battery leads and replace these with connection fixings suitable for the installed batteries.

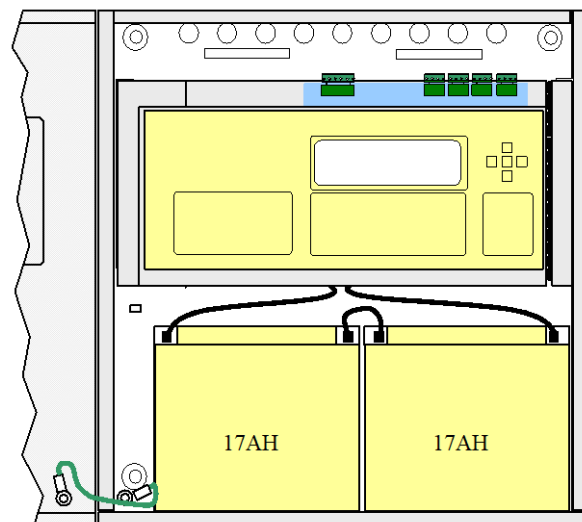
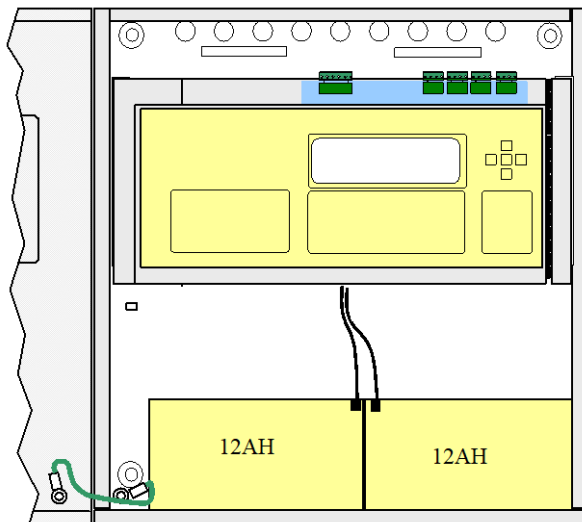

#### Replacement Fuse

FS1 T6.3A 250V Anti-Surge

### 2.7.2.3 Mx-4400/LE & Mx-4800

The diagrams opposite show the recommended location and orientation for the batteries within the panel for 17Ah, 25Ah and 38Ah batteries. The diagram shows the arrangement for the Mx-4800.

The Mx-4400/LE is only equipped with the upper chassis. Batteries up to 38Ah should be placed on the upper battery shelf. Batteries up to 48Ah can be supported – these should be formed by the parallel connection of 24Ah batteries located on both battery shelves.

Note: A separate power supply chassis can be fitted in the lower chassis position to provide power and mounting positions for peripheral options. Batteries for this can be located at the bottom of the enclosure.

For battery sizes greater than 12AH, it will be necessary to remove the spade terminals fixed to the battery leads and replace these with connection fixings suitable for the installed batteries.

Each battery shelf can hold batteries up to 38Ah.

#### Replacement Fuses

FS1 T6.3A 250V Anti-Surge (on each chassis)

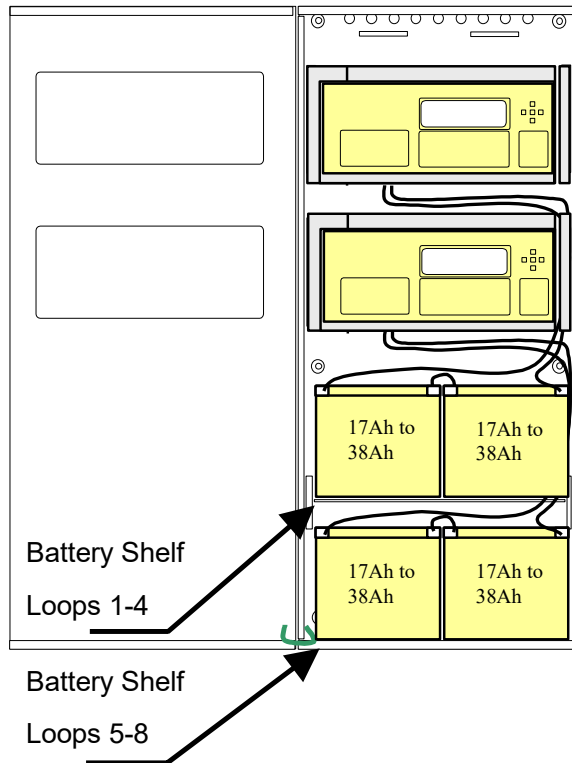

### 2.7.2.4 Battery Temperature Monitoring

Each of the base cards contains an on-board thermistor device to monitor the temperature in the enclosure.

For the Mx-4100 and Mx-4200 / Mx-4400 standard enclosures, this on-board thermistor is ideally situated to monitor the temperature of the batteries.

As the batteries installed in the Mx-4800 and Mx-4400/LE enclosures are located remote from the on-board sensor then the temperature gradient in the panel may result in an incorrect charging voltage (too low) being applied (depending on panel loading and internal heating effects).

A separate plug-in thermistor assembly should be used on the Mx-4800 and Mx-4400/LE (supplied with these panels).

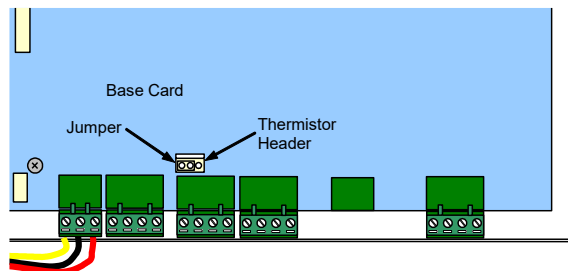



To use the plug-in thermistor:

Remove the jumper from, and plug-in the thermistor cable assembly to, the connector shown above. Route the thermistor cable assembly along with the battery wires and use the supplied tie-wrap to hold the thermistor sensor close to the top of the batteries.

DO NOT remove the jumper when an external thermistor is not employed.

## 2.7.3 Detector Loop Installation

|   |  |
|---|--|
|  <p>Section 12.5.2</p> | <p><b>Maximum of 32 Sensors / Call Points in a Zone (between Isolators).</b></p> <p>The Detection Loop Circuit should be installed as a continuous loop with isolator modules such that a short circuit condition does not remove more than one zone or 32 input devices.</p> <p>Refer to Section 5.5.4 for details on the use of Apollo Isolators.</p>                            |
|  <p>Section 13.7</p>   | <p><b>Not more than 512 fire detectors and / or manual call points and their associated mandatory functions shall be affected as a result of a system fault in the C.I.E.</b></p> <p>The panel (or each chassis in the Mx-4800) should be installed with not more than 512 fire input devices.</p> <p>See Appendix 9 for further details on Mx-4800 and network installations.</p> |

Form the loop starting at the Loop Out + and – terminals on the base card.

Route the wires around the loop connecting all devices in accordance with the manufacturers' data sheet supplied with each unit.

Ensure that the devices are correctly installed with regard to their positive and negative terminal polarity (especially Loop Isolator Modules).

Connect the return wires to the Loop IN + and – terminals on the base card.

The diagram opposite shows the typical arrangement of the loop connections on the base cards.

Refer to Section 2.5 for details on installing additional loop drivers on the multi-loop panels.

**It is recommended that shielded cable is used for the loops.**



**When screened cable is used, it is vital to connect the screen / drain wire to the chassis / earth at the cable gland input / earth stud in the panel. Always ensure that all segments of the cable loop have continuity of the screen and take care to ensure that the screen is not exposed to any other earth point (e.g. metalwork, cable trays, junction boxes, etc.).**

The Loop Driver Circuit on the Base card is equipped with in-built isolators to take care of short circuit conditions on the wiring between the panel and the first device on the loop. Do not fit loop isolators at the panel outputs.

The diagram opposite shows a typical loop arrangement.

Maximum recommended cable loop length is 1500 to 2000 Metres. Refer to [Appendix 2 – Recommended Fire Rated Cables](#) for further information on cable types to be used.

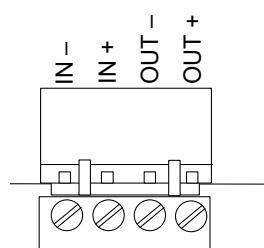

Base Card Terminations (Typical).

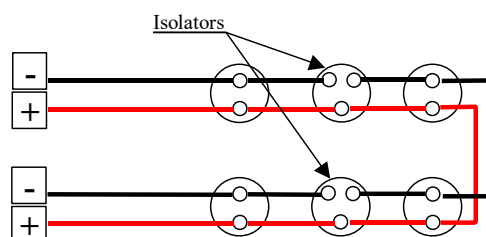

Typical Loop Arrangement.



**Take care that the voltage drop at full load is within the detector rating – refer to the detector manufacturers' data sheet for minimum values.**

**To maintain signal line wiring supervision, break the wiring run at each loop device.**

## 2.7.4 Sounder Circuits

The *Mx-4100* & *Mx4200* are equipped with two supervised sounder circuits. These are denoted as Circuits A and B.

The *Mx-4400* is equipped with four supervised sounder circuits. These are denoted as Circuits A, B, C and D.

The *Mx-4800* is equipped with two sets of four sounder circuits (eight in total).

Each Sounder output is rated at a maximum of 1 Ampere.

The terminal connections on the base card are shown in the diagram opposite.

The sounder outputs are monitored (supervised) for open and short circuit conditions using reverse polarity signals. Sounder must be equipped with an in-built blocking diode that prevents the sounder from taking power when the output is in the supervising condition.

An End-of-Line Resistor (EOLR) of value 10,000Ω, ½ Watt must be fitted to the last sounder / bell.

Refer to [Appendix 2 – Recommended Fire Rated Cables](#) for further information on cable types to be used.

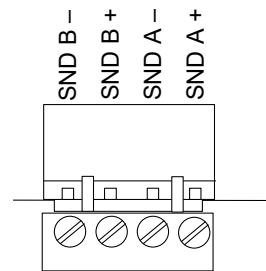

Base Card Connections – Typical.

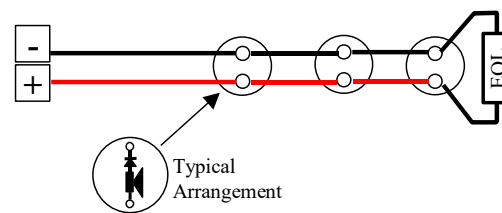

Typical Sounder Arrangement.



**When screened cable is used, it is vital to connect the screen to the chassis / earth at the cable gland input / earth stud in the panel. Always ensure that all segments of the cable loop have continuity of the screen and take care to ensure that the screen is not exposed to any other earth point (e.g. metalwork, cable trays, junction boxes, etc.).**

## 2.7.5 Relay Circuits

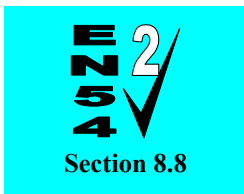

**Fault Output.**

**Relay 1 is arranged for failsafe operation as standard.**

The panels are equipped with two relay outputs. These are normally programmed to activate on Fault and Fire Alarm conditions respectively.

Each output is unsupervised with volt-free changeover contacts rated at 30V AC/DC, 1 Ampere.

The *Mx-4800* is equipped with two sets of relay outputs (four in total).

Optional relay cards are available if additional relays are required.

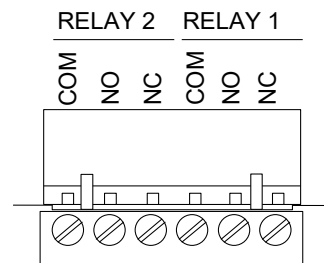

Base card arrangement – typical.

The Relay outputs can be used, instead of the Routing Interface Card, to provide non-monitored fire and fault routing outputs to appropriate routing equipment.

In this case, the panel will not indicate transmission path failures to the routing equipment – this feature must be incorporated into the routing equipment itself. [Not fully EN54-2 compliant].

### 2.7.6 Open Collector Outputs

The *Mx-4100*, *Mx-4200* & *Mx-4400* are equipped with two open collector type outputs that can sink up to 10mA each from the AUX Power Output.

The *Mx-4800* is equipped with four open collector type outputs (two per chassis) that can sink up to 10mA each from their respective AUX Power Output.

These are fully programmable and can be used to control external relays.

The connections of the base card are shown in the diagram opposite.

No external back-emf diodes are required.

The *Mx-4200* & *Mx-4400* are equipped with two open collector and six digital programmable outputs via a 10-pin connector – see opposite.

Up to 16 outputs are available on the *Mx-4800*.

An optional 8-way relay card is available to connect to this connector.

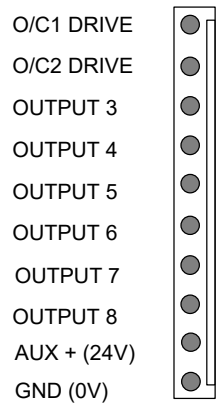
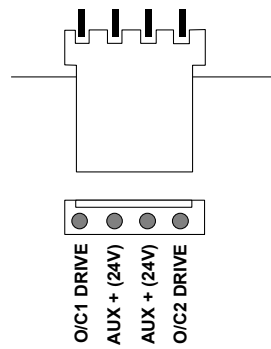

### 2.7.7 Auxiliary Supply Output

The *Mx-4100*, *Mx-4200* & *Mx-4400* are equipped with an auxiliary 24V DC, 500mA power supply output.

The *Mx-4800* is equipped with two such outputs (one per chassis).

These can be used for powering ancillary equipment and must only be used for powering localised internal equipment.

Base Card Connections.

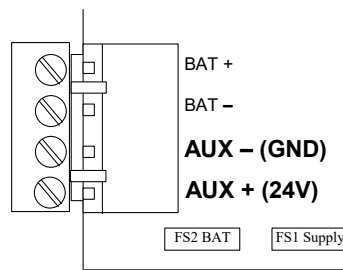

*Mx-4100*

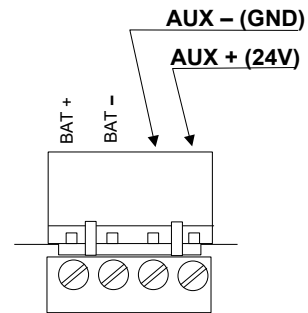

*Mx-4200/4400/4800*

### 2.7.8 Switch Inputs

Key switch inputs can be used for changing access level, performing “class change” etc. by changing the “Action” of these inputs. An optional 8 way input board is also available for this connector.

Up to 16 key-switch inputs can be accommodated on the *Mx-4800*.

Refer to separate Technical Data sheets for examples.

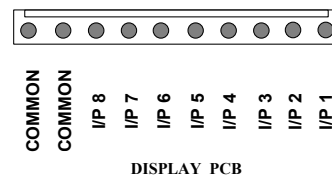

### 2.7.9 RS232 Interface

The *Mx-4100* is equipped with a non-isolated RS232 I/F Circuit at the bottom left-hand side of the base card.

The *Mx-4200* & *Mx-4400* are equipped with an isolated RS232 I/F Circuit at the bottom of the base card. The *Mx-4800* has two RS232 interfaces available (one per chassis).

The terminal block connections are shown opposite.

TX = Transmit Data from the panel, RX = Receive Data into the panel, GND = Ground Reference.

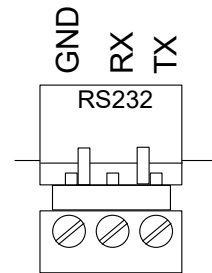

Base Card Connections – *typical*.

### 2.7.10 Isolated Bus Interface

The isolated bus interface is used to connect local peripheral equipment located internal to the panel or located within 10m of the panel.

The terminal block on the *Mx-4200/Mx-4400* base card is shown opposite. Connect the cable from 'A' to 'A' and from 'B' to 'B'. Equipment is connected via a daisy chain.

External connections should be made using fire rated cable or run in rigid metal conduit between enclosures.

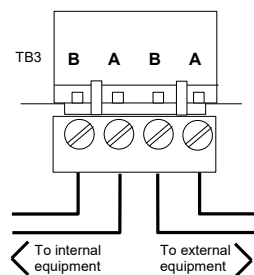

Base Card Connections – *typical*.

### 2.7.11 Routing Interface

The Routing Interface is used to output monitored signals to Fire Routing Equipment and Fault Routing Equipment.

Each function comprises of an output circuit.

Each output is monitored for open circuit and short circuit wiring conditions in both the activated and quiescent states and can be connected to a remote relay coil with a resistance of 1KΩ to 5KΩ. A suppression diode must be connected across the coil – observe connection polarities.

The Fault Output is normally energised during the quiescent condition – it will de-energise on any fault or on total loss of power.

For further information, refer to Document 680-081.

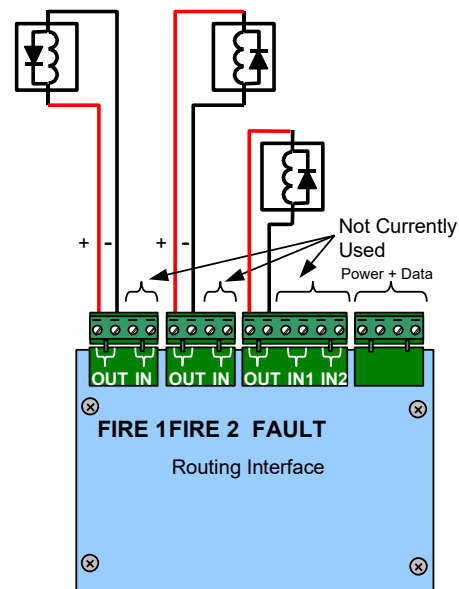

Typical Arrangement

Refer to [Appendix 2 – Recommended Fire Rated Cables](#) for further information on cable types to be used for these transmission paths.

## 3 Programming

### 3.1 Introduction

These instructions cover the configuration and programming of the panels.

Note 1: On the *Mx-4800*, each chassis assembly must be individually programmed.

Note 2: If field devices have been activated while in the level-3 menu a reset should be performed after returning to level-2.8

#### 3.1.1 Access Levels

The panel operation is protected from inadvertent and erroneous misuse by means of four access levels. These levels are as follows:

Level 1 Untrained user

Level 2 Authorised User

Level 3 Commissioning, Service and Maintenance

Level 4 Commissioning, Service and Maintenance – Special Tools Required

This document covers the Level 3 functions. For details on the operation and use of the panel at Levels 1 & 2, refer to User Manual 680-015. Full details are supplied with the special tools.

A level-3 password is required to enter the commissioning menus. For details of Passwords, refer to Section 3.3.11.



#### Level-3 Passwords.

If this number is lost, it is not possible to enter commission mode functions.

Refer to 5.1 for further formation.

#### 3.1.2 Memory Lock

The configuration memory may be protected against inadvertent change by means of a memory lock.

Before making any configuration data changes, move the jumper strap to the OPEN position.

After all changes have been made, move the jumper strap back to the CLOSE position to protect the memory against inadvertent change.

Refer to the diagram opposite for information on the jumper settings.

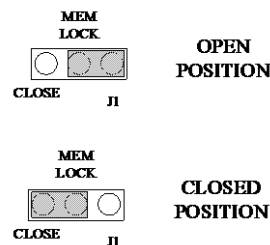

Typical View – *Mx-4100*

#### 3.1.3 Navigating through menus

The display will revert to status mode after 60s. Press the 'Menu' button to restore the display.

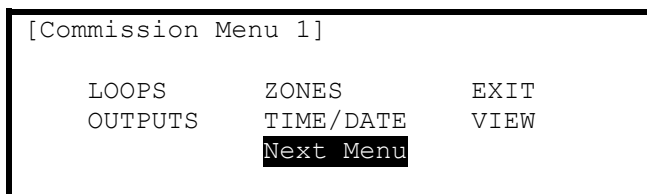

When a menu is displayed, use the ←↑↓→ buttons to highlight the required menu option and then press the ✓ button to select it.

Press the 'Esc' button from within a menu option to return to the previous menu.

The display can be forced back into status mode by pressing the 'Esc' button when at the top level commissioning menu (or by waiting 60s).

### 3.1.4 Changing Text Descriptions

Various parameters can have a text description defined. These include loop devices, zones, etc. The zone and device text descriptions will be shown on the display in the Fire Alarm, Fault and Warning Conditions, etc. to provide a quick and clear indication of the source of the problem.

To change the text description, first highlight the text description within the appropriate programming option and then press the ✓ button. The display then changes to show the text entry dialogue screen. For example:

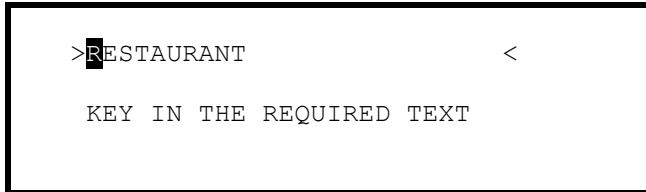

The method of entering the characters is similar to the method employed on mobile telephones. The number buttons provide both their appropriate number and several letters of the alphabet. An example of the keypad is shown opposite.

For example, Button 2 allows entry of the number 2 and letters A, B and C.

When a button is pressed, the number is first shown on the display at the current cursor position. If the button is pressed again within ½ second, the first character replaces the number. A further press displays the second available character and so on. After pressing the button to obtain the required character, wait for 1-second and the character will be entered and the cursor will move to the next character in the text description.

Pressing another button will immediately enter the previous character and move the cursor on to the next character.

Use the ←→ buttons to move backwards or forwards along the line. When the text description is as required, press the ✓ button to confirm the change.

If the text has been entered incorrectly, press the 'Esc' button to cancel all changes and return to the previous display.

The following table shows the numbers, characters and symbols assigned to each button on the keypad.

| Button | 1 <sup>st</sup> Press | 2 <sup>nd</sup> Press | 3 <sup>rd</sup> Press | 4 <sup>th</sup> Press | 5 <sup>th</sup> Press | Further Characters     |
|--------|-----------------------|-----------------------|-----------------------|-----------------------|-----------------------|------------------------|
| 1      | 1                     |                       |                       |                       |                       |                        |
| 2      | A                     | B                     | C                     | 2                     |                       | Ä, Æ, Å, À, Á, Â, Ã, Ç |
| 3      | D                     | E                     | F                     | 3                     |                       | È, É, Ê, Ë, Æ          |
| 4      | G                     | H                     | I                     | 4                     |                       | Ì, Í, Î, Ï             |
| 5      | J                     | K                     | L                     | 5                     |                       |                        |
| 6      | M                     | N                     | O                     | 6                     |                       | Ö, Ø, Ò, Ó, Ô, Õ, Ñ    |
| 7      | P                     | Q                     | R                     | S                     | 7                     |                        |
| 8      | T                     | U                     | V                     | 8                     |                       | Ù, Ú, Û, Ü             |
| 9      | W                     | X                     | Y                     | Z                     | 9                     | Ý, Þ                   |
| 0      | Blank                 | 0                     |                       |                       |                       |                        |

Alternatively, press the ↑↓ buttons to scroll through a list of characters. When the required character is shown, press the → button to move on to the next character. The list of characters available and the order of presentation is as follows:

Blank !"#%&'()\*+,-./ 0123456789 :;⇄?@ ABCDEFGHIJKLMNOPQRSTUVWXYZ [ ] ^ \_

### 3.1.5 Numeric data entry

Numbers are entered by moving to the required field, and then typing in the required number, followed by the ✓ button.

If the number is entered incorrectly, press the ‘Esc’ button to restore the previous number.

### 3.2 Recommended Programming Procedure

- ◆ Step 1 – SET-UP, Define General Set-up Information (Phone Numbers, etc.).
- ◆ Step 2 – PASSWORDS, Define Level 2 and Level 3 Passwords as required.
- ◆ Step 3 – AUTO-LEARN, Let the panel learn the devices on the loop(s).
- ◆ Step 4 – VIEW DEVICES, Enter Zone Numbers, Location text and Change Group Assignments if required.
- ◆ Step 5 – OUTPUTS, Program Output Groups as required.
- ◆ Step 6 – ZONES, Enter Zone Texts as required.

### 3.3 Level 3 Menu Functions

The following table gives a list of the Level 3 Menu Functions, the sub-functions available within each main function and a brief description for each function.

| Main Menu Option | Sub Menus | Comments                 |  |
|------------------|-----------|--------------------------|--|
| 4<br>3           | LOOPS     | View/Edit                | View, test and configure the loop devices                                    |
|                  |           | Auto Learn               | Learn the Devices Present on the Loop.                                       |
|                  |           | Calibrate                | Calibrates devices on the loop   |
| 6                | ZONES     | --                       | Configure the Zones.   |
|                  | EXIT      | --                       | Cancel Level 3 Access and return to Level 2 Menu Options.                    |
| 5                | OUTPUTS   | --                       | Configure the Operating Characteristics of the Output Circuits.              |
|                  | TIME/DATE | --                       | Change the Date and Time Settings.   |
|                  | VIEW      | Fires                    | View Zones and Inputs that are reporting a fire alarm condition.             |
|                  |           | Faults                   | View Zones and Inputs that are reporting a fault condition.                  |
|                  |           | Alarms                   | View Zones and Inputs that are reporting an alarm condition during test.     |
|                  |           | Disabled                 | View Zones, Inputs and Outputs that are disabled.                            |
|                  |           | Inputs                   | View the current state of Zones and Inputs.                                  |
|                  |           | Outputs                  | View the current operational condition of all output circuits.               |
|                  |           | Log                      | View the Event Log.  |
|                  |           | Panel                    | View the operational state, voltage & current loading of the panel I/O.      |
|                  | Network   | View Network Diagnostics |  |
| 2                | PASSWORDS | --                       | Configure the Level 2 and Level 3 passwords.                                 |
|                  | PANEL     | --                       | Change the default zone assignments and output groups for all panel I/O.     |
|                  | PC-LINK   | --                       | Enable the PC Link for transfer of configuration data to and from the panel. |
| 1                | SETUP     | --                       | Configure General Operating Parameters.                                      |

### 3.3.1 Loops

For Multi-loop panels only – On selecting the LOOPS option, the display will prompt for the loop to be viewed / programmed. E.g. for the *Mx-4400*: -

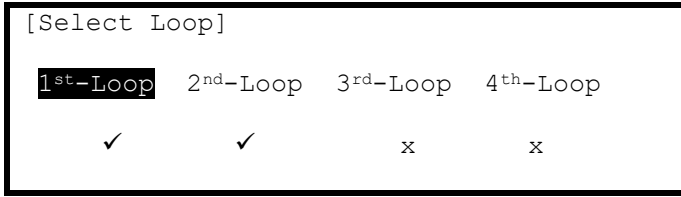

The list of loops available will be adjusted automatically to show only those loops that have a loop driver card installed. In the above example, loop drivers are installed in positions 1 and 2.

Press the **↑↓←→** buttons to scroll through the list of loops available and then press the **✓** button to select the loop required.

The display will then show a list of programming options as follows: (Note: On selecting the LOOPS option on the *Mx-4100*, this display will be shown directly).

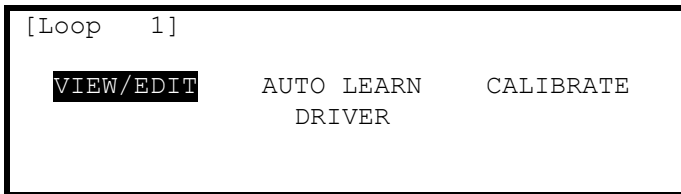

### 3.3.2 Loops – View/Edit

The VIEW/EDIT option shows a list of the devices connected to the loop learnt by the panel. For example:

| Address | State  | Type         | Value |
|---------|--------|--------------|-------|
| 001.0   | Normal | CALL POINT   | 16    |
| 002.0   | Normal | MULTI.SENSOR | 28    |
| 003.0   | Normal | ION SMOKE    | 23    |
| 004.0   | Normal | HEAT         | 21    |

The first device on the loop is shown at the top of the list and is highlighted. Press the **↑↓** buttons to scroll through the list of devices.

Press the **←→** buttons to view additional information. The display highlights a particular parameter. To change the value of this parameter (if not view only), press the **✓** button and appropriate options will be shown on the display.

#### 3.3.2.1 State

This parameter shows the current operational status of the device. For example, this can show Normal, Fire Alarm, Device Missing, etc.

This parameter cannot be changed.

#### 3.3.2.2 Type

This parameter shows the type of device learnt by the panel. For example, this can show Call Point, Multi-Sensor, ION Smoke, Heat, etc.

This parameter cannot be changed.

### 3.3.2.3 Value

This parameter shows the analogue value returned by the device. The number displayed will vary according to the type of device fitted. An 'H' (High) and 'L' (Low) is shown for logic inputs. This parameter cannot be changed.

### 3.3.2.4 Zone

This parameter shows the Zone to which this device has been assigned. Use the **number** keys to change the zone assigned to the device.

### 3.3.2.5 Device Text

This parameter shows the 26-character location text assigned to this device. For guidance on how to change the text, refer to Section 3.1.4.

### 3.3.2.6 Action

This parameter shows the action that will be performed when this device indicates an active (alarm) condition. For example:

| [Loop 1 Devices] |             | <More>          |
|------------------|-------------|-----------------|
| Address          | Action      | Sensitivity O/P |
| 001.0            | FIRE SIGNAL | DEFAULT         |
| 002.0            | FIRE SIGNAL | DEFAULT         |
| 003.0            | FIRE SIGNAL | DEFAULT         |
| 004.0            | FIRE SIGNAL | DEFAULT         |

Press the ✓ button to change the action assigned to this input device. A pop-up window is then shown on the display from which an action can be selected.

| [Select New Action] |
|---------------------|
| FIRE SIGNAL         |
| PRE-ALARM           |
| FAULT SIGNAL        |

Press the ↑↓ buttons to scroll through the list of Actions and then press the ✓ button to confirm the change. The display reverts to the device list showing the new action assigned to this device. Alternatively, press the 'Esc' button to cancel the changes and return to the device list display. The following Actions are available (Additional actions are available on a PC)

| Action                   | Description   |
|--------------------------|---|
| Fire Signal <sup>4</sup> | A Fire Alarm Condition will be generated whenever the input is active.  |
| Pre-Alarm                | A Pre-Alarm Condition will be generated whenever the input is active.   |
| Fault Signal             | A Fault Condition will be generated whenever the input is active.   |
| Security                 | A Security Alert Condition will be generated whenever the input is active.  |
| Record                   | A Record Entry will be stored in the Log whenever the input is active. This will be hidden from the panel status display. |
| Create Alarm 1           | An "Alarm 1" condition will be generated whenever this input is active.   |
| Create Alarm 2           | An "Alarm 2" condition will be generated whenever this input is active.   |
| Create Alarm 3           | An "Alarm 3" condition will be generated whenever this input is active.   |
| Key Lock                 | Enables / Inhibits front panel controls (Disable, Mute, Reset etc.)   |
| -                        | No Action is assigned to the input.   |
| Control Signal           | Allows control of Outputs without displaying "Fault" or "Fire" or sounding buzzer   |
| Acknowledge              | Activation of the input acknowledges a Stage 1 Investigation Delay and invokes the Stage 2 Timer                          |
| LED Test <sup>5</sup>    | Activation invokes a test of the panel LED Indicators.  |

### 3.3.2.7 Sensitivity

This parameter shows if the device sensitivity is set to its "DEFAULT" or "CUSTOM" settings. For example:

<sup>4</sup> Fire Alarm Conditions are latched. By default, all other conditions are non-latching. The action for smoke and certain other detectors is always fire and cannot be changed.

<sup>5</sup> LED Test can only be configured using the PC Tool.

```
[Loop 1 Devices] <More>
Address Sensitivity
001.0 DEFAULT
002.0 DEFAULT
003.0 CUSTOM
004.0 DEFAULT
```

Press the **✓** button to change the sensitivity assigned to an input device. When selected a new screen displays the sensitivity settings assigned. For example, with an Apollo Discovery

```
SENSITIVITY ADJUST MODE (ION SMOKE )
[ Alarm = 55 ]
[ Mode = 3 ][ Pre-Alarm= 45 ]
[ Delay = 5s][ Min.Value= 8 ]
[SAM/SSM]
```

Press the **←↑↓→** buttons to highlight the required menu option and then press the **✓** button to select it. Use the **number** buttons to enter the required value. Alternatively, press the **'Esc'** button to cancel the changes.

The alarm thresholds and delay times can be unique for every device if required.



**Always ensure that the values chosen are suitable for the particular installation and that reliable fire coverage is maintained at all times.**

### 3.3.2.7.1 Mode- Apollo:

This is applicable to Discovery devices only.

The panel fully supports the sensitivity modes within the Discovery devices. Refer to the Apollo technical documentation for a detailed description and recommended use of these bands.

Different sensitivity modes can be chosen for both day and night periods. This field can be set in the range 1 – 5.

### 3.3.2.7.2 Mode- Hochiki:

This is applicable to Multi-sensor devices only:

- Mode 0: (Default) Combined optical & heat detectors
- Mode 1: Optical mode only
- Mode 2: Heat mode only

### 3.3.2.7.3 Delay

The value in this field defines the delay from detecting an alarm to entering the alarm condition. The delay time can be changed in 1-second increments.

### 3.3.2.7.4 Alarm- Apollo

The Alarm Level is the level of the analogue value returned by the detector at which the panel will enter a Fire Alarm Condition. The default value is 55. Setting the value higher will mean that more smoke / higher temperature is required before the panel will enter the alarm condition. Setting the value lower will mean that less smoke / temperature is required before the panel will enter the fire alarm condition.

The alarm level cannot be set outside the safe operating limits defined for the particular device.

Apollo Discovery devices always use a value of 55.

### 3.3.2.7.5 Alarm- Hochiki

The Alarm Level of the Analogue value returned by the detector at which the panel will enter a fire condition is set to Hochiki Alarm thresholds (expressed as a % value) This is normally 3% for Multi-sensor & Optical devices. Refer to Hochiki Data Sheets for further information.

### 3.3.2.7.6 Pre-Alarm

The Pre-Alarm Level is the level of the analogue value returned by the detector at which the panel will enter a pre-alarm condition.

### 3.3.2.7.7 Minimum Value

If the detector analogue output falls below the minimum value programmed, the panel will enter a fault warning condition. This parameter is normally left at a value of 8 for Apollo detectors and 0 for Hochiki.

### 3.3.2.7.8 Special Sensitivity Mode SSM/Clock

In addition to the "SENSITIVITY ADJUST MODE", a device can also run in a "SPECIAL SENSITIVITY MODE" (SSM) under time-clock control.

The Mx4100 supports 3 independent, 7-day time clocks.

The Mx4200 supports 10 independent, 7-day time clocks.

The Mx4400 supports 10 independent, 7-day time clocks.

With the SAM/SSM Option highlighted, press the ✓ button to view the Special Sensitivity Mode settings. For example:

```

SPECIAL SENSITIVITY MODE (MULTI.SENSOR)

[SSM/Clock =      2 ][ Alarm =      55 ]
[ Mode =          5 ][ Pre-Alarm=    40 ]
[ Delay =         5s][ Min.Value=     8 ]
[SAM/SSM]

```

In the above example the panel is using special sensitivity mode 2 (and time clock number 2). Enter "0" in the SSM/Clock field to cancel Special Sensitivity Mode.

A number must be entered in the SSM/Clock field to select the appropriate SSM number and time clock. To view the time clock settings, highlight the SSM/Clock field, and press the ✓ button.

For example:

```

[Time Clock 2]
DAY      ON  -> OFF      ON  -> OFF
MON      00:00 00:00    19:00 00:00
TUE      00:00 06:30    00:00 00:00
WED      00:00 00:00    00:00 00:00
THU      00:00 00:00    00:00 00:00

```

The panel supports two independent times for each day of the week during which the SSM mode will be switched on (i.e. during which the Special Sensitivity Mode settings are active)

In the above example the SSM will be active between 19:00 on Monday and 06:30 on Tuesday.

Press the ←↑↓→ buttons to select the appropriate time field and use the **number** buttons to enter the required times. Press the 'Esc' button to return to the previous menu display.

Every type of device (the device type is shown in the top, right hand corner) supports unique SSM settings for each SSM/Clock number. In the previous example the Special Sensitivity Mode settings have been defined for a Multi-Sensor that is using SSM/Clock number 2. If other Multi-sensors on the same panel also require the same settings, then you only need to set them to SSM/Clock 2. If instead another Multi-Sensor requires a different setting, use a different SSM/Clock number.

### 3.3.2.8 O/P Group

The Output Group assigned to the Sounder or Relay Devices determines the manner in which the outputs will operate when a fire alarm or other programmed condition occurs.

For example:

| [Loop 1 Devices] |     |       | <More> |
|------------------|-----|-------|--------|
| Address          | O/P | Group |        |
| 020.0            | 199 |       |        |
| 021.0            | 199 |       |        |
| 022.0            | 199 |       |        |
| 023.0            | 199 |       |        |

Use the **number** buttons to change the value of the O/P Group setting.

By default, all Loop Output devices are assigned to Output Group 199.

For detailed information and guidance on the programming and use of Output Groups, refer to Section 5.4

### 3.3.2.9 Additional Info

This parameter shows additional information, if available, for this device. For example, the following display shows the Apollo detector series types:

| [Loop 1 Devices] |                 |  | <More> |
|------------------|-----------------|--|--------|
| Address          | Additional Info |  |        |
| 001.0            | Disco           |  |        |
| 002.0            | XP95            |  |        |
| 003.0            | Disco           |  |        |
| 004.0            | Disco           |  |        |

For further information on this option, refer to [Appendix 5 – Apollo Information](#) and [Appendix 6 – Hochiki ESP Information](#)

### 3.3.2.10 Device Testing

Individual detectors can be tested to check the chamber response and illuminate the detector LED and individual outputs (sounders and relays) can be tested to check output connections and operation.

While the address field is highlighted, press the **↑↓** buttons to scroll through the list of devices to the desired device (or key in the address, and then press the **✓** button).

| [Loop 1 Devices] |        |              |       | <More> |
|------------------|--------|--------------|-------|--------|
| Address          | State  | Type         | Value |        |
| 005.1            | Normal | SOUNDER      | -     |        |
| 006.0            | Normal | MULTI.SENSOR | 16    |        |
| 006.1            | Normal | RELAY        | -     |        |
| 007.0            | Normal | CALL POINT   | 16    |        |

A menu will appear to confirm that you want “Test This Device”.

Press the **✓** button to confirm or press the **‘Esc’** button to cancel.

Once selected, commands are sent to the detector to turn on the detector LED and put the chamber into test or are sent to the output device to turn the output on. The “Test” LED lights up and the panel display returns to the list of devices.

A few seconds after a detector is placed into test, the analogue signal will be seen to rise. If the detector is then left in the test condition, the Detector State will change to a “Fire Test” status.

The test is cancelled as soon as the display is scrolled up or down or when the ‘View Devices’ option is exited.

### 3.3.3 Loops – Auto Learn

#### 3.3.3.1 Normal Procedure / Initial learn

The panel can automatically learn the presence or absence of devices at all addresses connected to the loop. When the Auto Learn option is selected, the panel starts searching each address on the loop to locate and find all of the devices connected. A display is shown to indicate the progress of this procedure.

For example:

```
[Auto Learn Loop 1] HOCHIKI  
  
Address 15    Devices found = 3
```

When all addresses have been searched, the panel displays a summary screen showing the quantity of devices found for each type of device.

For example:

```
[Auto Learn Loop 1] HOCHIKI  
  
Address 127    Devices found = 4  
OPT ION MUL TMP MCP SCC I/O ZMU OTHERS  
0 1 1 1 1 0 0 0 0
```

This summary provides a quick check to ensure that the panel has found all of the devices that should be connected to the loop.

Press the 'Esc' button to return to the main Loops Menu.

#### 3.3.3.2 Procedure if the Panel finds Devices Missing

When the panel cannot communicate with a device previously programmed into the panel, the Auto Learn process is suspended and the display shows a pop-up window with options. For example:

```
KEEP THIS DEVICE  
DELETE THIS DEVICE  
KEEP ALL MISSING  
DELETE ALL MISSING  
  
! Address 002 DEVICE MISSING
```

If the missing device is kept (or all missing devices are kept), the panel remembers the programming for these devices. The panel will report a fault condition until such time as the missing devices are reconnected.

If the missing device is deleted (or all missing devices are deleted), the panel clears all previous programming for these devices. This includes any sensitivity threshold changes, text assignments, zone assignment, action, etc.

Press the  $\uparrow$  $\downarrow$  buttons to highlight the required menu option and then press the  $\checkmark$  button to confirm. The pop-up window will disappear and the panel will continue with the auto learn process.

If a single device is deleted and another missing device is subsequently registered, the display will once again show the pop-up window to keep or delete this device.

### 3.3.3.3 Procedure if the Panel finds Devices Added

When the panel finds a device not previously learnt and programmed in the panel, the Auto Learn process is suspended and the display shows a pop-up window with options. For example:



If the new device is accepted (or all new devices are accepted), the panel will configure the memory to register these devices. All data will be configured to initial settings for sensitivity threshold changes, text assignments, zone assignment, action, etc. for these devices.

If the new device is rejected (or all new devices are rejected), the panel clears all programming for these devices and will not attempt to communicate with the devices at these addresses.

Press the  $\uparrow\downarrow$  buttons to highlight the required menu option and then press the  $\checkmark$  button to confirm. The pop-up window will disappear and the panel will continue with the auto learn process.

If a single device is accepted / rejected and another new device is subsequently registered, the display will once again show the pop-up window to accept or reject this device.

### 3.3.3.4 Procedure if the Panel finds Devices Changed

When the panel finds a new type of device installed at an address previously learnt and programmed in the panel, the Auto Learn process is suspended and the display shows a pop-up window with options. For example:

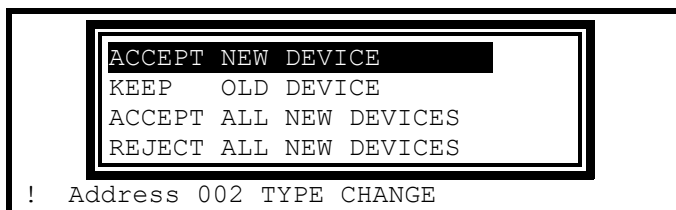

This situation could arise for example if a heat detector has been installed in place of an optical smoke detector.

If the new device type is accepted (or all new device types are accepted), the panel will configure the memory to register these devices. All data will be configured to initial settings for sensitivity threshold changes, text assignments, zone assignment, action, etc. for these devices.

If the new device type is rejected (or all new device types are rejected), the panel remembers the programming for the original devices. The panel will report a fault condition until such time as the correct device types are reconnected.

Press the  $\uparrow\downarrow$  buttons to highlight the required menu option and then press the  $\checkmark$  button to confirm. The pop-up window will disappear and the panel will continue with the auto learn process.

If a single device is accepted / rejected and another new device type is subsequently registered, the display will once again show the pop-up window to accept or reject this device.

## 3.3.4 Loop – Calibrate

Calibrates Hochiki devices – Note this can take up to several minutes if many detectors & sounder bases are installed.

## 3.3.5 Loop – Driver

Displays loop output and input voltages and loop loading.

A diagnostic display with automatic scanning of the loop to find devices with minimum and maximum communication pulse heights is available (for loop drivers manufactured after October 2002).

### 3.3.6 Zones

The Commission Zones option lists all the zones in use by the panel and allows the zone text description to be changed.

```
[Commission Zones]
Zone   Location
0001  BASEMENT WEST
0002  RECEPTION
0015  EAST WING
0018  TOWER BLOCK
```

To change the location text assigned to the Zone, press the ✓ button when the Zone Location Text is highlighted. Refer to Section 3.1.4 for guidance on how to change text descriptions.

To select a different zone, use either the scroll up/down keys, or just type in the number of the required zone, followed by the ✓ button. Note that only zones in use are displayed.

### 3.3.7 Exit

To exit the Commission Mode and return the panel to normal operation (i.e. level 2), select the “Exit” option. The display will prompt for confirmation of the level 3 password. For example:

```
[Commission Menu 1]
Please Enter Your Password
Next Menu
```

If the password is incorrect (this will be indicated) or if the password is not entered within 5-seconds, the display will revert to the Commission Level Menu and level-2 will not be entered.

After commissioning, the panel must always be returned to level 2 (or level 1) to give normal fire coverage.

### 3.3.8 Outputs

The “Cause and Effect” programming is a schedule of actions that will turn on one or more outputs dependant on a set of input events.

The Outputs Option provides the means to create simple or complex “cause and effect” programming within the panel. Delays can be introduced to allow a phased evacuation of a building (Note this is different to an “Investigation Delay” which is detailed in section 3.3.9).

This section describes the settings and options in detail for each parameter. Refer to [Appendix 4 – Cause and Effect Programming Example](#) for a description of how to program a typical requirement.

More complex “Cause and Effect” programming may be undertaken using the PC Configuration tool.

When the OUTPUTS Option is selected, the display shows the cause and effect programming for Output Group 1. For example:

```
[Output Group 1] [ 3.9% Mem used]
ZONE CAUSE STYLE=Delay->MODE Wait
1 ANY FIRE 00 - On
2 ANY FIRE 00 - On
3 ANY FIRE 00 - On
4 ANY FIRE 00 - On
```

To simplify the cause & effect programming, one or more outputs that will respond in the same way when the same set of input events occurs can be grouped together. This association of outputs is called an Output Group.

The panel can support up to 200 of these Output Groups.

To select a different Output Group, press the **↑** button to highlight the Output Group Number field and then enter the number of the output group required using the **number** buttons. The display always shows the Output Group is shown in the top left corner.

Press the **↑↓** buttons to scroll through the list of zones.

Press the **←→** buttons to select the fields for a particular zone.

Press the **✓** button to select a particular field option to change its setting.

### 3.3.8.1 Default Output Settings

On initial installation, or after clearing the configuration memory, all outputs are assigned to specific Output Groups and will turn on immediately a single fire alarm occurs in any zone (any fault condition for the fault relay). The default assignments are as follows:

| Output Device                         | Output Group | Cause and Effect                 |
|---------------------------------------|--------------|----------------------------------|
| On-board Sounder A                    | 1            | Any fire in any zone – no delay  |
| On-board Sounder B                    | 2            | Any fire in any zone – no delay  |
| On-board Sounder C <sup>6</sup>       | 3            | Any fire in any zone – no delay  |
| On-board Sounder D <sup>6</sup>       | 4            | Any fire in any zone – no delay  |
| On-board Relay 1 <sup>7</sup>         | 200          | Any fault in any zone – no delay |
| On-board Relay 2 <sup>7</sup>         | 199          | Any fire in any zone – no delay  |
| On-board Open Collectors <sup>7</sup> | 199          | Any fire in any zone – no delay  |
| Fault Routing Output <sup>8</sup>     | 200          | Any fault in any zone – no delay |
| Fire Routing Output-A <sup>8</sup>    | 199          | Any fire in any zone – no delay  |
| Fire Routing Output-B <sup>8</sup>    | 199          | Any fire in any zone – no delay  |
| All Loop Output Devices               | 199          | Any fire in any zone – no delay  |

### 3.3.8.2 Cause

Each Output Group can be programmed to respond in a unique way to events from each individual zone. An input event may be a fire alarm condition or it may be a fault, disablement or other condition. A combination of criteria may also be applied to each zone.

The Cause field determines what type of input event (or a combination of input events) will generate an output response for the selected input zone.

```

[Output Group 1]      [ 3.9% Mem used]
ZONE  CAUSE          STYLE=Delay->MODE  Wait
  1   ANY FIRE       00    -    On
  2   ANY FIRE+     00    -    On
  3   ANY FIRE       00    -    On
  4   ANY FIRE       00    -    On
    
```

Press the **✓** button to change the setting and a pop-up window will appear showing the options available. For example:

```

[FIRE ] [D/K FIRE]   [ALARM] [PRE-ALARM]
  ✓      -           -           -
[FAULT] [I/P DISABLE] [TEST ] [ CONTROL ]
  -      -           -           -
    
```

Press the **←↑↓→** buttons to highlight the required menu option and then press the **✓** to change its setting. An input action type is enabled when a '✓' is shown beneath the option. It is permitted to select multiple input types in which case a combination of input events will result in an output action. If there is a combination of input

<sup>6</sup> Mx-4400 Only

<sup>7</sup> This Output is used for routing if the non-monitored routing option is selected.

<sup>8</sup> This Output is available on the optional Routing Interface Peripheral Card.

events, the CAUSE display above shows this extended programming by adding a '+' to the text. For example, Zone 2 above shows that the basic event is ANY FIRE + other criteria.

Press the 'Esc' button to return to the previous display.

The definition for each cause is as follows:

| Cause              | Definition  |
|--------------------|---|
| Fire               | Any single fire.  |
| Double Knock (D/K) | Coincidence of 2 or more fire detectors or a single manual call point in the same zone. |
| Alarm              | Activation of an input device programmed with an 'Alarm' action.                        |
| Pre-Alarm          | A device in a pre-alarm condition.  |
| Fault              | Any device entering a fault condition.  |
| Input Disabled     | Whenever an input device is disabled.   |
| Test               | A 'Walk Test' fire in the zone.   |
| Control            | A control input in this zone will cause activation.                                     |



**Section 7.12**

**Coincidence Detection.**

**The operation of the Coincidence Detection (Double Knock) feature is on a per zone basis.**

### 3.3.8.3 Style

The way in which an output turns on in response to a particular input event can be programmed. For example, an output may turn on immediately, it may turn on after a delay or it may pulse for a set time and then turn on. This method of operation is called a Style. A style may have up to three different methods of operation. For example,

Delay → Mode, Wait → Mode, Wait → Mode.

Style 00 is fixed to turn on immediately an input event occurs.

Style 01 is fixed to pulse immediately an input event occurs.

Styles 02 to 20 are programmable (02 to 10 on *Mx-4100*).

Press the → button to step on to the style field. Change the setting using number entry to select the required output style. If the style is already programmed elsewhere, the relevant style parameters are automatically entered into the appropriate fields.

#### 3.3.8.3.1 Delay

The delay field is the time from qualification of the input event to something happening at the output. The delay time can be set in intervals of 1 second up to a maximum of 250 seconds.

Press the → button to step on to the delay field and change the setting using number entry.

#### 3.3.8.3.2 Mode

The mode field defines the method of operation of the output when it is first activated. This can be ON or PULSE.

Press the → button to step on to the delay field and change the setting using the ✓ button.

Note: Pulse settings are by default 1-second ON / 1-second OFF. Other pulse options can be specified on the PC Tool (such as 2s ON / 3s OFF) – these can be assigned to on-board outputs only.

#### 3.3.8.3.3 Wait

The wait field is the time from first activation of the output to the next operational condition (mode) of the output. For example, the output could initially be delayed for 20 seconds and turn on in a pulsing mode. After a wait of a

further 30 seconds it can be programmed to turn on differently such as ON. The wait time can be set in intervals of 1 second up to a maximum of 250 seconds.

Press the → button to step on to the wait field and change the setting using number entry.

#### 3.3.8.4 Copying Output Settings to Multiple Zones

To save time in the entry of similar Output Group Settings for each zone, it is possible to copy information programmed for a particular zone to subsequent zones.

Press the ← button to highlight the required zone number and then press the ✓ button. The display shows a pop-up window prompting for the number of the zone to which to copy the information.

Use the number entry to select the required zone number. The Output Group programming for all of the zones from the currently selected zone to the zone number entered will be programmed with the same information as the currently selected zone.

### 3.3.9 Investigation Delays

In addition to the “Cause and Effect” programming described above, the panels also support an “Investigation Delay Mode” which allows time for a building supervisor to investigate fire signals before turning outputs on. This mode can only be configured from the PC software.

There are two parts to this delay. The first stage is set relatively short. If the building supervisor does not acknowledge the fire signal within the first stage, the delayed outputs will turn on. The second stage gives a longer period to investigate the fire signal. This delay can be cancelled at any time by pressing the EVACUATE button, or any nominated input devices (by default, all call points cancel this mode).

Each input and output device can be individually programmed to use the investigation delay from the PC configuration software, together with the times appropriate to each stage of the delay. The user manual gives details of how the building occupier can turn the investigation delay feature on or off.



**Delays to Outputs.**

**It must be possible to override the operation of any delays at Level 1. Refer to Section 3.3.9.1 for information on overriding delays.**

**For compliance, the maximum total delay permitted is 10 minutes.**

**Section 7.11**

#### 3.3.9.1 Overriding Delays at Level 1

A facility to override any programmed delays and immediately activate the sounder circuits should be provided at Level 1. It is possible to override the delay using the panel controls (see the user manual for details). This can also be achieved from an input device (such as a manual call point) that is programmed to turn on all outputs immediately.

### 3.3.10 Time and Date

This function allows the time and date in the panel to be changed. On entry to the function, the display shows the current time and date with confirmation of the day of the week on the bottom line. For example:

```
[SET TIME/DATE]

TIME = 15:28
DATE = 15/04/02    MON 15 APR 2002
```

To change the settings, use the ↑↓ buttons to highlight the required option. Directly enter the new time or date using the **number** buttons. As soon as a **number** button is pressed, the display will clear the current setting and show the new value as it is entered. For example:

```
[SET TIME/DATE]

TIME = 1█:--
DATE = 15/04/02    MON 15 APR 2002
```

## View Options

The View Menu Options are identical to those available during Level-2 operation.

For further information on the View Options and the information that is presented, refer to the User Manual (Document No. 680-015).

### 3.3.11 Passwords

The panel provides up to 10 User Level-2 passwords and 2 Level-3 passwords. All of the passwords<sup>9</sup> can be changed.

On entry to the function, the display shows a list of the passwords. For example:

| Password | Access level | User ID |
|----------|--------------|---------|
| 15633    | 2            | 01      |
| 9988     | 2            | 02      |
| 13344    | 2            | 03      |
| 10000    | 2            | 04      |
| 10000    | 2            | 05      |

To change a password, use the **↑↓** buttons to highlight the required password and then enter the new password using the **number** buttons. When the password is correct, press the **✓** button to confirm.



#### Level-3 Passwords.

**Care should be taken when changing the Level-3 password. If this new number is lost, it is not possible to enter commission mode functions.**

**Refer to 5.1 for further information.**



**The factory default level 3 password is 7654**

### 3.3.12 Panel

The Panel Menu Option shows a list of the internal panel circuits and provides a means to change their default configuration settings.

Only use this menu if changes are to be made to the default settings for the panel's internal circuits. Use the VIEW-PANEL Menu Option to view the state and operating condition of each circuit.

The display shows for example:

| Address | State  | Type    | More><br>Value |
|---------|--------|---------|----------------|
| >001.0  | Normal | VOLTAGE | 5.6V           |
| 001.1   | Normal | VOLTAGE | 5.6V           |
| 002.0   | Normal | CURRENT | 0mA            |
| 002.1   | Normal | CURRENT | 0mA            |

Use the **↑↓** buttons to scroll through the circuits. Use the **←→** buttons to view additional information. The zone and Output Group Assignments can be modified if required.

For further information on the View – Panel Options and the information that is presented, refer to the User Manual (Document No. 680-015).

#### 3.3.12.1 AC Fail Delay

The panel can be configured to delay the reporting of a loss of AC Mains supply (Address 14.0).

<sup>9</sup> The passwords can be further qualified using the PC CONFIG TOOL to provide permission / restriction to specific menu options. See User Manual 680-015 and PC CONFIG TOOL Manual for further details.

The front panel Green Power LED will still immediately flash on the loss of the AC Supply, but the fault condition is only reported after the delay time (default 10s) has elapsed.

```
SENSITIVITY ADJUST MODE (MONITOR )
                                [ Alarm = *** ]
                                [ Pre-Alarm= *** ]
[ Delay = 10s] [ Min.Value= 372 ]
[SAM/SSM]
```

To delay the reporting of an AC Supply Loss, change the “Delay” setting<sup>10</sup>.

### 3.3.13 PC Config

The PC Link Option enables the connection of the PC Configuration Tool for retrieving configuration data from the panel and programming configuration data from a file on the PC.

For further information, refer to the Manual supplied with the PC Configuration Tool.

### 3.3.14 Setup

The Setup Options Menu enables the configuration of panel generic operating parameters. When the option is selected, the display shows a list of the available parameters. For example:

```
[Setup]
THIS NETWORK NODE : 0
NEXT NETWORK NODE : 0
PANEL ZONE       : 100
SERVICE NUMBER  : 01234 567890
```

Use the  $\uparrow\downarrow$  buttons to scroll through the list of options. The following will then be shown:

```
[Setup]
SERVICE DUE DATE : 1 JAN 2011 10:00
TRACE LOGGING MODE : STANDARD More>
DETECTOR BLINKING : NONE
COMPANY LCD LOGO  : ✓
```

#### 3.3.14.1 Network

This Network node is set to 0 for a standard non-networked panel. For panels in a networked application please refer to the Network document, reference: 680-027.

#### 3.3.14.2 Panel Zone

By default all the panel inputs are assigned to the Panel Zone. Alternatively the PC configuration program allows individual inputs to have different zones if required.

#### 3.3.14.3 Service Number

The Service Number is the telephone number that is shown on the status display whenever a fault condition occurs. To change the number, press the  $\checkmark$  button when the option is highlighted. The number is entered using the text entry facility; refer to Section 3.1.4 for guidance on how to enter text.

<sup>10</sup> For compliance with EN54-4, the loss of the AC Mains supply should not be delayed more than 30 minutes (1800s).

### 3.3.14.4 Service Due Date

The next service (over) due date can be entered into the panel memory. When this date is reached, the panel will enter a fault condition to alert the site operator that a service visit is overdue. To change the due date, press the ✓ button when the option is highlighted. The display prompts for entry of the next service date. For example:

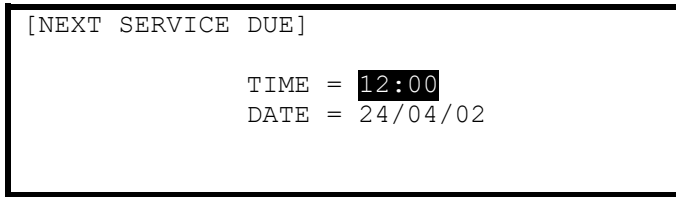

Use the ↑↓ buttons to select between the time and date. Use the number buttons to enter the required time or date.

As soon as a new service date is entered, the panel will cancel any Service Due Fault condition.

### 3.3.14.5 Trace Logging Mode

The Trace Logging Option determines what type of information and to what level is stored in the Event Log.

There are three options:

STANDARD = the normal operating mode logging fire alarm, fault and warning conditions as they occur.

STANDARD + = an extended version of the standard operating mode where the removal of fault and warning conditions are also logged.

DIAGNOSTIC = a full diagnostic trace of all conditions with greater depth to aid diagnosis of fault conditions.

To change the option, press the ✓ button.

To erase the event log, press the → button to view the additional command option as follows:

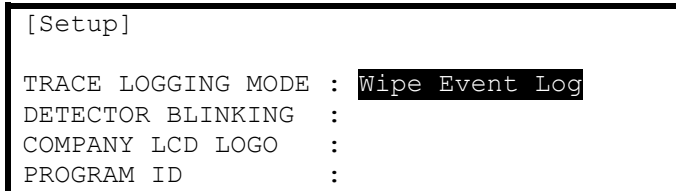

Press the ✓ button and the display will show that the event log is being erased by display the message “WORKING...” After the event log is erased, the display reverts to the Set-up Options screen.

### 3.3.14.6 Detector Blinking

The Detector Blinking option determines whether the LED indicators on the devices will blink whenever the panel polls the device. To change the operation, press the ✓ button. The display presents a list of options. For example:

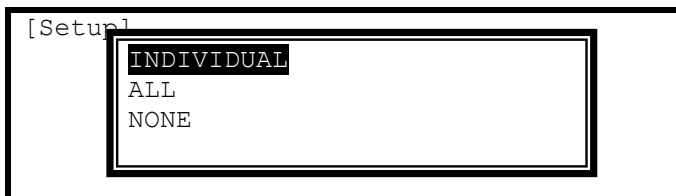

Use the ↑↓ buttons to scroll through the list of options and press the ✓ button to confirm the selection.

The device LED indicators will not blink if NONE is chosen or will blink if ALL is chosen. Note that only certain devices, such as Apollo Discovery, support this feature.

If a device, such as a Discovery device, is changed it may be necessary to select and reconfirm the blinking command so that the new device will blink its LED.

The INDIVIDUAL option should be chosen when it is required that only certain devices should blink their LED. The devices that shall blink their LED can only be programmed using the PC Configuration Tool.

### 3.3.14.7 Earth Fault Notification

This parameter determines whether an Earth Fault is shown on the display during normal operation. To change the setting, press the ✓ button. The status changes from ✓ to X and vice versa.

### 3.3.14.8 Routing Interface

This parameter determines whether the panel supports a fire and / or fault routing interface. It is possible to select between no routing interfaces, monitored routing interfaces (requires installation of the Routing Interface Peripheral Card and non-monitored routing interface using the on-board fire and fault relays. To change the setting, press the ✓ button. With each press, the option cycles between X, Monitored and Non-Monitored.

When a routing option is selected, Function LED1 (Red) is used to indicate that the Fire Routing Output is activated and Function LED2 (Yellow) is used to indicate that the Fire Routing Output is disabled. If the monitored option is selected, Function LED3 (Yellow) is used to indicate a fault in the transmission path of the fire routing connection. Function LED3 will also illuminate if there is a fault on the routing interface or if the routing interface card is not present.

If a routing option is selected, these function LED indicators are reserved for these indications and are not available for other programmable indication use.

By default, the fire routing output (panel internal addresses – 11.1 unmonitored & 16.0 monitored) and the fault routing output (panel internal addresses 11.0 unmonitored & 17.0 monitored) are assigned to Output Groups 199 & 200, respectively. These can be assigned to alternative output groups using the "Panel" menu option if required.

By default, the fire routing output will be activated if there is fire in any zone. The output is configured not to turn on in the event of a fire test even if the output group rule contains this option.

By default, the fault routing output will be turned off if there is a fault in any zone.

### 3.3.14.9 Resound Alarms

This parameter determines, under an alarms-silenced condition, what new activation will lead to the alarms being re-sounded.

There are two options:

**NEW ZONE IN FIRE** = alarms will only be re-sounded if a new device activation occurs in a zone not already active. If a device activation occurs in a zone already active then the sounders will remain silenced.

**NEW DEVICE IN FIRE** = alarms will be re-sounded for any new device activation regardless of zone.

Note: the following input actions can cause alarms to re-sound:- FIRE; PRE-ALARM; ALARM-1; ALARM-2; ALARM-3.

To change the option, press the ✓ button, the default setting is NEW ZONE IN FIRE.

### 3.3.14.10 Program ID

The display shows the part number and version of the software installed in the panel. Press the → button to see the program checksum (8 digits)

### 3.3.14.11 Config Data

The Config Data option shows the loop protocol selected and the checksum for the configuration data. A note of this number can be taken and then checked on the next service visit to see if any changes have been made to the configuration data.

In addition, there is an option to erase the Config Data.

To view the Config Data Checksum, press the → button. The display then shows:

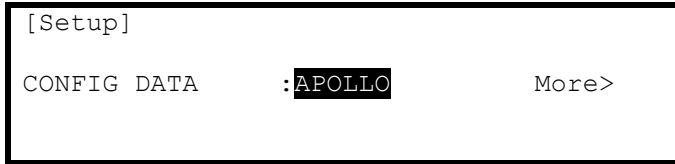

To change the protocol, press the ✓ button. A pop up window is shown with the following options



Use the ↑↓ buttons to select the required options and press the ✓ button to confirm the selection.

Selecting "CHANGE LOOP PROTOCOL" will toggle to the alternative loop protocol available (i.e.: Apollo/Hochiki)



**Changing between protocols will automatically erase all loop devices from the configuration memory.  
Perform an "Auto-Learn" or use the PC Config Tool to re-define the devices connected to the loop.**

## 4 Service and Maintenance

### 4.1 Maintenance Schedule

This equipment should be maintained in accordance with the regulations and codes appropriate to the country and location of installation. The following is recommended if no other regulations apply.

#### 4.1.1 Daily Actions

The site operator / user should perform the following checks and actions:

- a) The panel indicates normal operation. If any faults exist, these should be recorded in a logbook.
- b) Any recorded faults have received attention and have been signed off.

#### 4.1.2 Monthly Actions

The site operator / user should perform the following checks and actions:

- a) Any stand-by generators should be started and fuel levels checked.
- b) Operate at least one call point or detector (from different zones each month) and check that the panel enters a fire alarm condition and that the appropriate / programmed alarm or warning devices are sounded / operated. Where permissible, this should include any links to the fire brigade or remote centre.
- c) Check that all outstanding faults have been recorded and have received attention.

#### 4.1.3 Quarterly Actions

The service / maintenance contractor should perform the following checks and actions:

- a) Check that all entries in the logbook have been addressed, check the event log in the panel and take the necessary remedial actions.
- b) Visually inspect the panel for any moisture ingress or other deterioration, check all battery connections and test / check the alarm, fault and other functions of the panel operation.
- c) Ascertain if any building or structural alterations have been carried out that would affect the placement / location of call points or detectors. If so, perform a visual inspection.
- d) Record in the logbook any defects or remedial actions that must be undertaken and arrange for these to be carried out as soon as possible.

#### 4.1.4 Annual Actions

The service / maintenance contractor should perform the following checks and actions:

- a) Perform the checks as recommended above in the daily, monthly and quarterly schedules.
- b) Perform a complete "Walk Test" of the system to check that each call point and detector is operating to its manufacturers' specification.
- c) Visually inspect all cable fittings. Check that the equipment is undamaged and that the conditions of installation have not changed such that they fall outside of the equipment specifications.
- d) Inspect and test all batteries and replace as required – refer to Section 4.2 for recommended replacement schedule.
- e) Record in the logbook any defects or remedial actions that must be undertaken and arrange for these to be carried out as soon as possible.

## 4.2 Replacement of Components

In general, all of the components parts used in the construction of the panel have been selected for long life and reliability.

However, certain components may require to be changed on a regular service basis. The details of these are as follows:

### 4.2.1 Batteries

For battery installation, see section [2.7.2](#)



**Respect the Environment.**

**Batteries must be disposed of responsibly and in accordance with any local regulations.**

#### 4.2.1.1 Standby Batteries

Expected Life: - 3-5 years at an ambient temperature of 20°C

Replacement Schedule: - As above. However, note that the expected battery life is shortened by increase in ambient temperature. The life reduces by 50% for every 10°C rise above ambient. Refer to battery manufacturer for further information.

|                                 |      |            |      |             |
|---------------------------------|------|------------|------|-------------|
| Manufacturer / Part Numbers:    | -    | Yuasa      |      | Powersonic  |
|                                 | 4Ah  | NP4-12FR   | 5Ah  | PS-1250 FR  |
|                                 | 7Ah  | NP7-12FR   | 7Ah  | PS-1270 FR  |
|                                 | 12Ah | NP12-12FR  | 12Ah | PS-12120 FR |
|                                 | 17Ah | NP17-12IFR | 18Ah | PS-12170 FR |
|                                 | 24Ah | NP24-12BFR | 26Ah | PS-12260 FR |
|                                 | 38Ah | NP38-12FR  | 38Ah | PS-12380 FR |
| Batteries connected in parallel |      |            | 45Ah | PS-12450-FR |



For optimum performance and charge retention, Yuasa recommend that batteries are 'top-charged' prior to installation.

For batteries up to 6 months old from date of manufacture, charge at 2.4V per cell (i.e. 14.4V per battery) for 20 hours prior to installing the batteries.

It is not recommended to use batteries that are more than 6 months old, from their date of manufacture, on a new installation.



**DANGER**  
Harmful fumes

It is quite normal for lead-acid batteries to vent hydrogen when being charged.

The panel is adequately ventilated to dissipate this hydrogen. DO NOT seal the enclosure or install in a sealed enclosure or cavity.

#### 4.2.1.2 Lithium Battery



**CAUTION – RISK OF EXPLOSION IF BATTERY IS REPLACED BY AN INCORRECT TYPE. DISPOSE OF USED BATTERIES ACCORDING TO THE INSTRUCTIONS.**

**A lithium battery is used for the real time clock.**

**Replace only with the same type or authorised equivalent. This battery is not rechargeable.**

**When the battery is replaced, re-enter the current date and time, using the menu functions, to update the values in the real-time clock chip.**

- Expected Shelf Life: - > 10 years
- Replacement Schedule: - 10 years for panels in continuous service  
10 years for spares (i.e. when the panel or card is not powered)  
Replace if the battery voltage falls below 2.6 volts.
- Manufacturer / Part Number: - CR2032

#### 4.2.2 Liquid Crystal Display

- Expected Life: - > 10 years
- Replacement Schedule: - When the display becomes difficult to read. The display contrast will gradually fade with time.
- Manufacturer / Part Number: - Replace the complete display / keyboard assembly. Spare part number MXS 004.

## 5 Appendices

### 5.1 Appendix 1 – Forgotten Level 3 Password

Should the Level-3 password be forgotten, contact Customer Support to obtain a temporary permit number to regain access to the panel programming functions.

Customer Support will require a decryption key displayed by the panel. To obtain this number, attempt to gain access to the Level-3 Programming Functions by pressing button “1” when prompted for the password. As soon as the “Password Invalid” message is shown, press the “0” button and the display will show a decryption key. Make a note of the first part of this number.

For example:

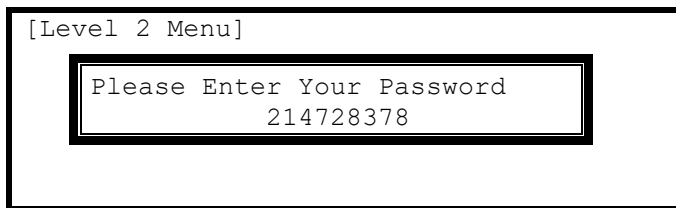

Customer Support will provide a temporary permit number that you can enter when prompted for the Level-3 password. As soon as access has been regained to the Level-3 Programming Functions, select the Passwords Menu Option and check / change the Level-3 password. (Refer to Section [3.3.11](#) for further information).

## 5.2 Appendix 2 – Recommended Fire Rated Cables

The following table provides a list of suitable fire rated cables with standard (30 minute) and enhanced (120 minute) classification. Refer to Document No. 680-088 for an up to date list.

| Manufacturer               | Cable Type  | Core Sizes (mm) |     |     | 5839-1 Rated |         | Net |
|----------------------------|---|-----------------|-----|-----|--------------|---------|-----|
|                            |   | 1.0             | 1.5 | 2.5 | S (30)       | E (120) |     |
| AEI                        | Firetec Multicore Ref. F1C                                      | ✓               | ✓   | ✓   |              |         | ✓   |
| AEI                        | Firetec Armoured Ref. F1C                                       | ✓               | ✓   | ✓   |              |         | ✓   |
| Calflex                    | Calflam CWZ<br>(2.5mm <sup>2</sup> )                            |                 |     | ✓   |              |         |     |
| Cavice SpA                 | Firecel SR/114H   | ✓               | ✓   |     | ✓            |         |     |
| Cavice SpA                 | Firecel SR/114E   | ✓               | ✓   | ✓   |              | ✓       |     |
| Draka                      | Firetuf (OHLS) FTZ  | ✓               | ✓   |     | ✓            |         | ✓   |
| Draka                      | Firetuf PLUS  | ✓               | ✓   | ✓   |              | ✓       |     |
| Huber & Suhner             | Radox FRBS/M1x2   |                 | ✓   | ✓   |              |         | ✓   |
| Irish Driver-Harris Co Ltd | Kilflam 2000  | ✓               | ✓   | ✓   | ✓            |         |     |
| Irish Driver-Harris Co Ltd | Kilflam 3000  | ✓               | ✓   | ✓   |              | ✓       |     |
| Pirelli                    | FP200 Flex<br>(1.0mm <sup>2</sup> )                             | ✓               |     |     |              |         | ✓   |
| Pirelli                    | FP200 Gold<br>(1.0mm <sup>2</sup> )                             | ✓               | ✓   | ✓   | ✓            |         | ✓   |
| Pirelli                    | FP PLUS   | ✓               | ✓   | ✓   |              | ✓       |     |
| Tratos Cavi SpA            | FIRE-safe TW950   | ✓               | ✓   | ✓   | ✓            |         |     |
| Tyco Thermal Controls      | Mineral Insulated Twin Twisted PYRO-E CCM2T                     | ✓               | ✓   | ✓   |              |         | ✓   |
| Tyco Thermal Controls      | Pyrotenax Served Mineral Insulated Cable (light and heavy duty) | ✓               | ✓   | ✓   |              | ✓       |     |
| Tyco Thermal Control       | Pyro-S  | ✓               | ✓   | ✓   | ✓            |         |     |
| Wrexham                    | Mineral Insulated Cable (light and heavy duty)                  | ✓               | ✓   | ✓   |              | ✓       |     |

### 5.2.1 Detector Loop Lengths

With the above cables, loops can be up to 2Km in length. However, care must be taken when designing the system to take into account the maximum loop loading. The voltage drop (load current x cable resistance) over the cable always needs to be taken into account to ensure the devices receive an adequate supply voltage. The following table gives recommendations for a loop. (It may be possible to extend the lengths where the devices are distributed evenly – refer to the Apollo/ Hochiki data sheets and Loop Calculators for further information on calculating loop loading, cable cross sectional area and loop distance).

|   |       |
|---|-------|
| Maximum Circuit Impedance                         | 72Ω   |
| Maximum Capacitance (Core-Core)                   | 230nF |
| Maximum Capacitance (Core-Screen)                 | 410nF |
| Insulation Resistance (Core-Core and Core-Screen) | ≥2M Ω |

NB: Maximum Circuit Impedance is the sum of the resistance of both cable conductors.

| Circuit Loading | Max. Circuit Impedance | Loop Cable Distance (M) |                    |                    |
|-----------------|------------------------|-------------------------|--------------------|--------------------|
|                 |                        | 1.0mm <sup>2</sup>      | 1.5mm <sup>2</sup> | 2.5mm <sup>2</sup> |
| 100mA           | 55.0Ω                  | 1500                    | 2000               | 2000               |
| 200mA           | 27.5Ω                  | 760                     | 1130               | 1860               |
| 300mA           | 18.3Ω                  | 500                     | 750                | 1200               |
| 400mA           | 13.7Ω                  | 380                     | 560                | 920                |
| 500mA           | 11.0Ω                  | 300                     | 450                | 740                |

### 5.2.2 Sounder Circuit Lengths

The voltage drop on each alarm circuit should be calculated to ensure that the minimum voltage at the end of the circuit exceeds the minimum required by each sounding device at the minimum alarm circuit output voltage.

The voltage at the end of the circuit is given by:

$$\text{Minimum Alarm Voltage} = V_{\text{OUT(MIN)}} - (I_{\text{ALARM}} \times R_{\text{CABLE}})$$

Minimum Output Voltage ( $V_{\text{OUT(MIN)}}$ ) is  $V_{\text{BAT(MIN)}} - 0.5V = 20.5V$

Alarm Current ( $I_{\text{ALARM}}$ ) is the sum of the loads presented by the sounding devices in alarm

Cable Resistance ( $R_{\text{CABLE}}$ ) is the sum of the cable resistance in both cores x cable length.

Cable Resistance ( $R_{\text{CABLE}}$ ) for 1.0mm<sup>2</sup> is 0.036Ω / metre

Cable Resistance ( $R_{\text{CABLE}}$ ) for 1.5mm<sup>2</sup> is 0.024Ω / metre

Cable Resistance ( $R_{\text{CABLE}}$ ) for 2.5mm<sup>2</sup> is 0.015Ω / metre

|  |       |
|--|-------|
| Insulation Resistance<br>(Core-Core and Core-Screen) | ≥2M Ω |
|--|-------|

### 5.2.3 Fire / Fault Routing Circuit Lengths

The voltage drop on each transmission circuit should be calculated to ensure that the minimum voltage at the end of the circuit exceeds the minimum required by the relay coil at the minimum circuit output voltage.

Typically, relays will energise at 75% of their nominal drive voltage (i.e. 18V for a 24V coil)

The voltage at the end of the circuit is given by:

$$\text{Minimum Coil Voltage} = V_{\text{OUT(MIN)}} - (I_{\text{ON}} \times R_{\text{CABLE}})$$

Minimum Output Voltage ( $V_{\text{OUT(MIN)}}$ ) is  $V_{\text{AUX(MIN)}} - 0.8V = 19.7V$

Maximum On Current ( $I_{\text{ON}}$ ) is 35mA.

Cable Resistance ( $R_{\text{CABLE}}$ ) is as above.

|  |       |
|--|-------|
| Insulation Resistance<br>(Core-Core and Core-Screen) | ≥2M Ω |
|--|-------|

### 5.2.4 Network Cables

For a list of recommended cables, refer to the AdNeT document 680-027.

### 5.3 Appendix 3 – Battery Standby Calculation Chart

Use the following charts and associated notes to calculate the size of the batteries required to ensure operation of the installation in the event of AC Mains power failure.

#### 5.3.1 Mx-4100

| Equipment                             | Quiescent Load          |   |                   | Fire Alarm Load              |      |            |
|---------------------------------------|-------------------------|---|-------------------|------------------------------|------|------------|
|                                       | I (A)                   | x   | Total             | I (A)                        | x    | Total      |
| <i>Mx-4100</i>                        | 0.115                   | 1.0   | = 0.115           | 0.225                        | 1.0  | = 0.225    |
| Sensor / Loop Current <sup>11</sup>   |                         | 1.25 <sup>12</sup>                                | =                 |                              | 1.25 | =          |
| Mxp-003 AdNeT Network Card            | 0.020                   | 1.0   | =                 | 0.020                        | 1.0  | =          |
| Mxp-009 AdNeT PLUS Network Card       | 0.062                   | 1.0   | =                 | 0.062                        | 1.0  | =          |
| Mxp-024 LED Indicator – 20 Zone       | 0.003                   | 1.0   | =                 | 0.012                        | 1.0  | =          |
| Auxiliary Supply Output <sup>13</sup> |                         | 1.0   | =                 |                              | 1.0  | =          |
|                                       |                         |   |                   |                              |      |            |
| Sounder Output A                      |                         |   |                   |                              | 1.0  | =          |
| Sounder Output B                      |                         |   |                   |                              | 1.0  | =          |
| Total                                 | $\Sigma$ Quiescent Load |   | =                 | $\Sigma$ Alarm Load          |      | =          |
|                                       |                         | x 24 hr =   | Ahr               |                              |      |            |
|                                       |                         | x 48 hr =   | Ahr               |                              |      |            |
|                                       |                         | x 72 hr =   | Ahr               | x 2 <sup>14</sup> x 0.5 hr = |      | Ahr        |
|                                       |                         |   | ↵ (carry forward) | +                            |      | Ahr        |
|                                       |                         | <b>Total Load (Quiescent + Alarm) =</b>           |                   |                              |      | <b>Ahr</b> |
|                                       |                         | x 1.25 <sup>14</sup> (Battery De-rating factor) = |                   |                              |      | <b>Ahr</b> |

<sup>11</sup> Use the detector manufacturers' technical information to calculate the load on the loop for both the quiescent condition and fire alarm condition for all loop devices. By default, a maximum of 5 detector / call point LED indicators will be turned on in a fire alarm condition. (This number can be changed via the PC Programming Tool).

<sup>12</sup> The calculated loop loading must be multiplied by a factor of 1.25 to calculate the actual current draw from the batteries. This is to take into account voltage conversion and conversion efficiency in generating the supply for the loop.

<sup>13</sup> Refer to separate data sheets for the additional modules that can be powered from the panel AUX Output to determine the AUX loading currents. For example, the modules can include Modem, Sounder Splitter, Routing Interface, etc. The sum of all these additional currents should be entered in these fields.

<sup>14</sup> The alarm load should be doubled to allow for changes in battery efficiency for loads in excess of the recommended C/20 discharge rate. The total load calculated should be multiplied by a de-rating factor of 1.25 to allow for changes in battery efficiency over time. The above calculation is in accordance with the recommendations in BS5839-1:2013.

### 5.3.2 Mx-4200 / Mx-4400 / Mx-4800

| Equipment                             |                      | Quiescent Load                                    |     |                    | Fire Alarm Load       |                              |         |
|---------------------------------------|----------------------|---|-----|--------------------|-----------------------|------------------------------|---------|
|                                       |                      | I (A)   | x   | Total              | I (A)                 | x                            | Total   |
| <i>Mx-4400/Mx4200 Chassis</i>         |                      | 0.083   | 1.0 | = 0.083            | 0.178                 | 1.0                          | = 0.178 |
| Loop Driver                           | Loop 1               | 0.042   | 1.0 | =                  | 0.042                 | 1.0                          | =       |
| Sensor / Loop Current <sup>15</sup>   |                      |   |     | 1.25 <sup>16</sup> | =                     |                              | 1.25    |
| Loop Driver                           | Loop 2               | 0.042   | 1.0 | =                  | 0.042                 | 1.0                          | =       |
| Sensor / Loop Current                 |                      |   |     | 1.25               | =                     |                              | 1.25    |
| Loop Driver                           | Loop 3 <sup>17</sup> | 0.042   | 1.0 | =                  | 0.042                 | 1.0                          | =       |
| Sensor / Loop Current                 |                      |   |     | 1.25               | =                     |                              | 1.25    |
| Loop Driver                           | Loop 4 <sup>17</sup> | 0.042   | 1.0 | =                  | 0.042                 | 1.0                          | =       |
| Sensor / Loop Current                 |                      |   |     | 1.25               | =                     |                              | 1.25    |
| Mxp-003 AdNeT Network Card            |                      | 0.020   | 1.0 | =                  | 0.020                 | 1.0                          | =       |
| Mxp-009 AdNeT PLUS Network Card       |                      | 0.062   | 1.0 | =                  | 0.062                 | 1.0                          | =       |
| Mxp-025 LED Indicator – 20 Zone       |                      | 0.003   | 1.0 | =                  | 0.012                 | 1.0                          | =       |
| Mxp-013-050 / 100 LED Indicator       |                      | 0.003   | 1.0 | =                  | 0.027                 | 1.0                          | =       |
| Mxp-012 Internal Printer              |                      | 0.020   | 1.0 | =                  | 0.025                 | 1.0                          | =       |
| Auxiliary Supply Output <sup>18</sup> |                      |   | 1.0 | =                  |                       | 1.0                          | =       |
| Sounder Output A                      |                      |   |     |                    |                       | 1.0                          | =       |
| Sounder Output B                      |                      |   |     |                    |                       | 1.0                          | =       |
| Sounder Output C <sup>17</sup>        |                      |   |     |                    |                       | 1.0                          | =       |
| Sounder Output D <sup>17</sup>        |                      |   |     |                    |                       | 1.0                          | =       |
| Total                                 |                      | $\Sigma$ Quiescent Load =                         |     |                    | $\Sigma$ Alarm Load = |                              |         |
|                                       |                      | x 24 hr =   |     |                    | Ahr                   |                              |         |
|                                       |                      | x 48 hr =   |     |                    | Ahr                   |                              |         |
|                                       |                      | x 72 hr =   |     |                    | Ahr                   | x 2 <sup>19</sup> x 0.5 hr = | Ahr     |
|                                       |                      |   |     |                    | ↵ (carry forward)     | +                            | Ahr     |
|                                       |                      | Total Load (Quiescent + Alarm) =                  |     |                    |                       |                              | Ahr     |
|                                       |                      | x 1.25 <sup>19</sup> (Battery De-rating factor) = |     |                    |                       |                              | Ahr     |

This chart is applicable to each chassis in the *Mx-4800* panel.

<sup>15</sup> Use the detector manufacturers' technical information to calculate the load on the loop for both the quiescent condition and fire alarm condition for all loop devices. By default, a maximum of 5 detector / call point LED indicators will be turned on in a fire alarm condition. (This number can be changed via the PC Programming Tool).

<sup>16</sup> The calculated loop loading must be multiplied by a factor of 1.25 to calculate the actual current draw from the batteries. This is to take into account voltage conversion and conversion efficiency in generating the supply for the loop.

<sup>17</sup> Not available on Mx-4200.

<sup>18</sup> Refer to separate data sheets for the additional modules can be powered from the panel AUX Output to determine the AUX loading currents. For example, the modules can include 8-Way Output, 8-way Input, Modem, Sounder Splitter, Shop Interface, etc. The sum of all these additional currents should be entered in these fields.

<sup>19</sup> The alarm load should be doubled to allow for changes in battery efficiency for loads in excess of the recommended C/20 discharge rate. The total load calculated should be multiplied by a de-rating factor of 1.25 to allow for changes in battery efficiency over time. The above calculation is in accordance with the recommendations in BS5839-1: 2002.

## 5.4 Appendix 4 – Cause and Effect Programming Example

### 5.4.1 Introduction

By default, all sounders and output devices will turn on immediately as soon as a fire is detected anywhere in the system. For example:

| <b>Cause</b>        | <b>Effect</b>                     |
|---------------------|-----------------------------------|
| Any Fire, Anywhere. | → ALL Output Devices will Turn ON |

Quite often an installation will require a more complex “Cause and Effect” solution. Consider a multiple story building where phased evacuation is required when a fire occurs on a particular floor. For example:

| <b>Cause</b>                                     | <b>Effect</b>  |
|--|--|
| Any Fire on Floor 7<br>(From Zones 22, 23 or 24) | → Sounders on Floor 6 will DELAY for 30 seconds, then start PULSING. After 2 minutes turn ON |
|  | → Sounders on Floor 7 will Turn ON   |
|  | → Sounders on Floor 8 will DELAY for 30 seconds, then start PULSING. After 2 minutes turn ON |

### 5.4.2 Output Groups

There may be several sounders on each floor. These can be grouped together using the Output Groups so that a single group number can easily reference all sounders on a particular floor in the panel. For example:

| <b>Sounders</b>                | <b>Output Group</b> |
|--------------------------------|---------------------|
| Assign All Sounders of Floor 6 | → Output Group 6    |
| Assign All Sounders of Floor 7 | → Output Group 7    |
| Assign All Sounders of Floor 8 | → Output Group 8    |

Refer to Section 3.3.2.8 for how to assign the output group to a loop output device. Refer to Section 3.3.8.1 for how to assign the output group to an internal panel circuit.

### 5.4.3 Styles

In the example, there are two ways in which the sounders should ring. These two operational characteristics can be defined as Styles in the panel. For example:

The first Style is that the sounders should turn on immediately a fire is recognised in Zone 22 or in Zone 23 or in Zone 24. The panel contains a default Style (Style 00) for this method of operation.

The second Style is that the sounders should stay silent for 30 seconds and then start pulsing. After 2 minutes of pulsing, they should then turn on. This is a little more complex but is easy to program. In the following description, a new Style (Style 2) will be defined for this purpose.

It is quite likely that Style 2 will be used extensively in the cause and effect programming for the rest of the building. For example, a fire on Floor 8 may also require the sounders on Floors 7 and 8 to operate in this manner.

## 5.4.4 Output Group Programming

To achieve the above cause and effect requirements, the three different Output Groups would be programmed and indicated on the panel as in the following display examples:

Output Group 6 – Sounders on Floor 6:

| [Output Group 6] |          | [ 3.9% Mem used] |      | [STYLE 02 ] |      |      |      |
|------------------|----------|------------------|------|-------------|------|------|------|
| ZONE             | CAUSE    | STYLE=Delay->    | MODE | Wait        | MODE | Wait | MODE |
| 22               | ANY FIRE | 02               | 30s  | Pulse       | 120s |      | On   |
| 23               | ANY FIRE | 02               | 30s  | Pulse       | 120s |      | On   |
| 24               | ANY FIRE | 02               | 30s  | Pulse       | 120s |      | On   |

More>

Output Group 7 – Sounders on Floor 7:

| [Output Group 7] |          | [ 3.9% Mem used] |      | [STYLE 00 ] |      |      |      |
|------------------|----------|------------------|------|-------------|------|------|------|
| ZONE             | CAUSE    | STYLE=Delay->    | MODE | Wait        | MODE | Wait | MODE |
| 22               | ANY FIRE | 00               | -    | On          |      |      |      |
| 23               | ANY FIRE | 00               | -    | On          |      |      |      |
| 24               | ANY FIRE | 00               | -    | On          |      |      |      |

More>

Output Group 8 – Sounders on Floor 8:

| [Output Group 8] |          | [ 3.9% Mem used] |      | [STYLE 02 ] |      |      |      |
|------------------|----------|------------------|------|-------------|------|------|------|
| ZONE             | CAUSE    | STYLE=Delay->    | MODE | Wait        | MODE | Wait | MODE |
| 22               | ANY FIRE | 02               | 30s  | Pulse       | 120s |      | On   |
| 23               | ANY FIRE | 02               | 30s  | Pulse       | 120s |      | On   |
| 24               | ANY FIRE | 02               | 30s  | Pulse       | 120s |      | On   |

More>

## 5.5 Appendix 5 – Apollo Information

Special Discovery specific features are available from the “Additional Info” field of the Loop View/Edit display. It is then possible to view the internal Drift, perform a rapid compensation or access any of the internal Discovery EEPROM memory locations. Press the ✓ button and a pop-up window is shown presenting a list of options.

For example:



Press the ↑↓ buttons to highlight the required menu option and then press the ✓ button to confirm.

### 5.5.1 View Drift

The display then shows the Discovery devices that the panel is reading. For example, select the View Drift option and the display shows:

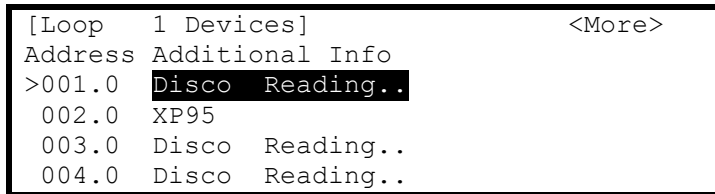

When the reading is complete, the display shows the drift within the device. For example:

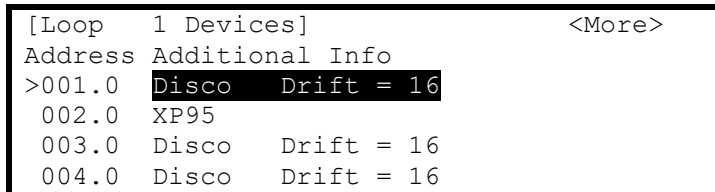

Refer to Apollo's literature for an explanation of the drift mechanism and for further information on the expected values.

### 5.5.2 Rapid Compensation

Apollo has incorporated a rapid compensation facility into the Discovery devices. If a device is changed during service it can be quickly adjusted to the present ambient conditions.

Highlight the required “Disco” family device, select RAPID COMPENSATION and then press the ✓ button to confirm. The panel will now instruct this device to perform a rapid compensation. This will take approximately 30 seconds.



**This operation must only be performed with the detector in clean air.  
No other operation should be performed on this device during this rapid compensation period.**

### 5.5.3 View EEPROM

The panel can read any of the extended memory locations within the Discovery devices.

Highlight any “Disco” family device, select VIEW EEPROM and then press the ✓ button to confirm. The display will prompt for entry of the required extended memory address. For example:

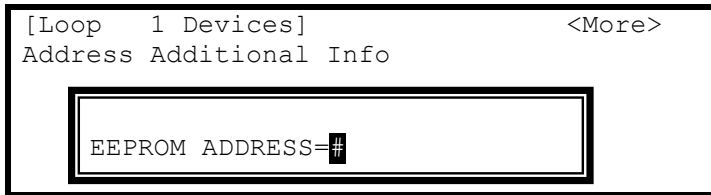

Enter the required address using the number buttons and then press the ✓ button to confirm.

The panel will now read the extended memory locations for all Discovery devices on the loop. When complete, the display will present the information as follows:

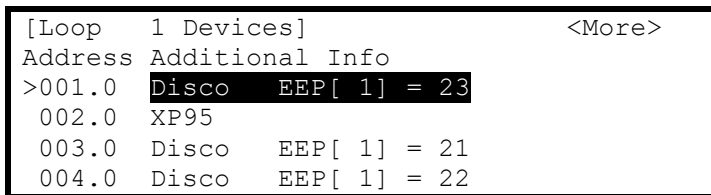

Refer to Apollo’s literature for an explanation of the extended memory locations and for further information on the expected values.

### 5.5.4 Loop Isolators

Apollo recommends a maximum of 20 detector devices (or equivalent loading) between isolators.

Note that some devices (particularly modules) are specified as representing the equivalent of two or more detector loads.

For further information, refer to the Apollo Document on Isolators (number PP2090) and individual Apollo device data sheets.

### 5.5.5 Sounder Group Addressing

The panel supports the optional “Group Address” now available on a number of the Apollo sounder type modules and sounders.

Refer to Document 680-128 for further information.

## 5.6 Appendix 6 – Hochiki ESP Information

At power up the panel allows a couple of minutes for Hochiki ESP detectors to stabilise. Any detectors that the panel knows to be present will then be calibrated. The panel displays can be used normally during this time, but the fire detection response will be slower until all the calibration phases are complete. If devices are inspected during this period, they may show their state as: -

- “Reset” - panel has reset the device at power up, resetting from a fire etc.
- “Calibrating” - checking ESP “Zero Point” and “Fire Points”
- “Initialising” - loading detection thresholds, sounder volumes etc.

Calibration can be manually initiated any time at access level 3, forcing all the devices on the selected loop to be calibrated. Transferring new device information from a PC to the panel will also cause the effected devices to be re-calibrated.

Periodic re-calibration can be performed at levels 1 & 2 under control of one of the 7-day time clocks. The time clock settings are configured from PC program.

### 5.6.1 Unprocessed Analogue information

For most purposes the “Value” field in the View/Edit menu gives the easiest to read and the most useful information from a detector as it is scaled and displayed in standard engineering units. It is, however, possible to see the unprocessed analogue signal (AN) by moving to the Additional Info field.

| [Loop 1 Devices] |                 | <More> |
|------------------|-----------------|--------|
| Address          | Additional Info |        |
| 001.0            | AN = 85         |        |
| 002.0            | AN = 81         |        |
| 003.0            | AN = 97         |        |
| 004.0            | AN = 83         |        |

Press the ✓ button to cycle through and display the stored Calibration Zero-point (ZP) and the Calibration Fire-point (FP).

### 5.6.2 CHQ-BS / CHQ-WS Sounders

Unlike standard sounders, these loop-driven sounders can be programmed to give out many different tones and be individually programmed to adjust the sound output. When programmed from the panel they will default to turn on at 85dB. Use one of the many tones available from the PC instead of the standard “Pulse” option if any special ringing is required.

The panel utilises the “group” features of the CHQ-BS/WS, so that when a command is sent to turn one device on, all other CHQ-BS/WS devices within the same group will turn on at virtually the same time from the same command (and likewise when they are silenced). Allocate unique “Output Groups” to CHQ-BS/WS devices, with no other device types using that group.

## 5.7 Appendix 7 – Mx4000 Series Loop Output Drive Capability

The following information is applicable per loop. All loops can be loaded to the maximum (500mA per loop). Provision has been made to allow for a typical loading of detectors and inputs (30mA).

### 5.7.1 Hochiki

| Volume | Number of Loop Powered Sounder Bases |
|--------|--------------------------------------|
| 98db   | 29                                   |
| or     |                                      |
| 95db   | 42                                   |
| or     |                                      |
| 94db   | 47                                   |
| or     |                                      |
| 93db   | 58                                   |
| or     |                                      |
| 90db   | 72                                   |
| or     |                                      |
| 88db   | 104                                  |
| or     |                                      |
| 85db   | 127                                  |

### 5.7.2 Apollo

| Volume | Number of Loop Powered Sounders |
|--------|---------------------------------|
| 100db  | 104 Loop Powered Sounders       |
| or     |                                 |
| 92db   | 57 Sounder Bases                |
| or     |                                 |
| 85db   | 126 Sounder Bases               |



The number of devices shown is representative for specific loop arrangements. If there is a mixture of sounder types or sounder volumes on the installation or if the other devices on the loop take more than 30mA in quiescent or alarm, then calculate the actual current load in alarm using the current consumption figures quoted in the device data sheets and ensure that this does not exceed the maximum output for the loop.

Refer to Section 5.2.1 and to Apollo and Hochiki Loop Calculators for further information on calculating loop loading, cable cross sectional area and loop distance.

## 5.8 Appendix 8 – Other Useful Documents

The following reference and application documents may be useful in the design, configuration and installation of the system.

The latest versions are available from the Advanced Electronics Ltd web site ([www.advancedco.com](http://www.advancedco.com)) or in hard copy format from Sales.

| Document Number | Title                          | Type             | Description  |
|-----------------|--------------------------------|------------------|--|
| 680-021         | Configuration Tool Software    | Level 3 Tool     | Explains how to configure the panel using the PC-NET-003 PC Software.<br>NOTE: On-line help is provided within the PC Software.  |
| 680-023         | Logo Software                  | Level 4 Tool     | Explains how to create and update the logo in the panel using the PC-NET-007 PC software.  |
| 680-025         | Key Switch Access Control      | Application Note | Explains how to configure the panel for use of a key switch for level 2 access.  |
| 680-027         | <b>Ad-NeT</b> Network          | Product Data     | Explains how to install and configure the <b>Ad-NeT</b> and <b>Ad-NeT-Plus</b> networks.   |
| 680-030         | Flash Programming              | Level 4 Tool     | Explains how to update the panel firmware with new software revisions.   |
| 680-034         | External Printer Output        | Application Note | Explains how to configure the panel and connect a serial RS232 printer.  |
| 680-039         | Class Change Programming       | Application Note | Provides examples of how to implement a class change function using different inputs.  |
| 680-042         | Gated Time-Clock Programming   | Application Note | Explains how to use an input to enable / disable a time-click function.  |
| 680-058         | Hochiki Sounders and Outputs   | Application Note | Explains how to configure the panel for operation with the ranges of sounders and output devices. Also details limitations.  |
| 680-059         | Apollo Ancillary Base Sounders | Application Note | Explains how to configure the panel for operation with detector LED driven base sounders. Also details limitations.  |
| 680-082         | Mx-4000 Door Replacement       | Application Note | Explains how to change the door / cover on the Mx-4000 Series panels/  |
| 680-085         | Software Upgrades              | Application Note | Explains how to upgrade the software in the Graphics Display Card and Fault Tolerant Network Card. Refer to 680-030 for general panel software flash programming information and guidance. |
| 680-088         | Cables for Fire Systems        | Application Note | Gives further information on the cables than can be used with the Mx-4000 Series.  |
| 680-089         | Zone Indications               | Application Note | Explains the options / optional modules to provide zone based indication in accordance with the requirements in BS5839-1: 2002.  |
| 680-110         | Apollo S90 Series              | Application Note | Details the devices supported and provide tips on working with these devices.  |
| 680-114         | Mx-4000 Series Approvals       | Application Note | Details the base approvals and 3 <sup>rd</sup> part testing for compliance with EN54 and LV & EMC directives.  |
| 680-116         | Minimizing False Alarms        | Application Note | Details the diverse methods that can be configured in the Mx-4000 Series to assist in the reduction of false alarms.   |
| 680-128         | Apollo Group Sounders          | Application Note | Details the configuration requirements to use the Apollo Sounder Group Addresses.  |
| 680-129         | LCD Contrast Adjustment        | Application Note | Details how to adjust the LCD contrast ratio / viewing angle   |

## 5.9 Appendix 9 – Mx-4800 / Network Design Principles

This section gives recommendations on the design of the installation to cover specific EN54-2 requirements and typical national codes of practice.

[EN54-2: 1997, Clause 13.7] Not more than 512 fire detectors and / or manual call points and their associated mandatory functions shall be affected as a result of a system fault in the C.I.E.

### 5.9.1 Mandatory Functions

For full compliance with the requirements in EN54-2, the configuration and operation of all mandatory outputs shall comply with the guidelines below.

Sounder Devices [EN54-2: 1997 Clause 7.8]:

Care should be taken with the cause and effect programming to ensure that any sounder / sounder output is configured such that its fire response operation will only be affected if there is a system fault on the chassis / panel to which it is directly connected.

Consideration should also be given to the applicable code of practice or national standard regulations for fire systems installation (for example BS5839-1: 2002) for installation and operation of sounder devices.

Fire & Fault Routing [EN54-2: 1997 Clauses 7.9 & 8.9]:

Mx-4800: If provided, then separate fire and fault routing interfaces should be provided on each chassis. These should be individually configured to report fire and fault conditions from their respective chassis / panel.

Network: If provided, then at least two fire and fault routing interfaces should be provided. These should be programmed to report all fire and all fault conditions.

### 5.9.2 Network Wiring

Where the installation design and codes of practice deem the network connections to be a 'Critical Signal Path' then consideration should be given to the use of the *Ad-NeT-Plus*<sup>®</sup> Fault Tolerant Network. For further information see document 680-027.

In addition, the routing and type of cables employed is important to limit the risk of multiple failures causing overall or partial loss of the network functions. BS5839-1: 2002 Sections 24-2 and 26.2 provide a useful guide.

- Use fire resisting cables.
- Configure the network as a loop.
- Employ diverse routing of incoming and outgoing circuits, except in the immediate vicinity of the sub-panel.
- There is no loss of communication to any sub-panel in the event of a single open or short circuit on the loop.

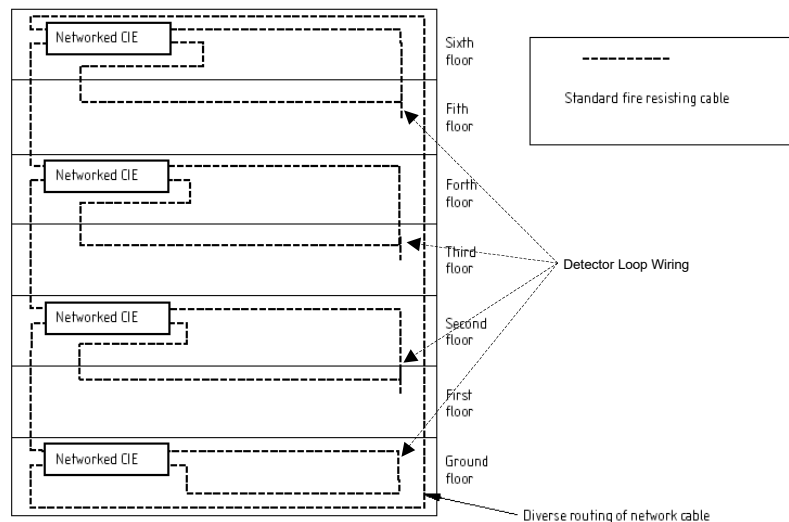

## 5.10 Appendix 10 – Mx Series Product Capabilities / Max Limits

This section gives details on the maximum capabilities for each of the products in the range. Some of the items can only be utilised via the PC CONFIG tool and these are annotated accordingly.

| Item   | 4100 | 4200 | 4400 | 4010 / 4020 | Mxp-010         | Mxp-020                            | Comments   |
|--|------|------|------|-------------|-----------------|------------------------------------|--|
| Max № of Loops                               | 1    | 2    | 4    | 0           | 0               | 0                                  |  |
| Max № of Resident Zones                      | 100  | 200  | 200  | 100         | 100             | 100                                |  |
| Highest Resident Zone №                      | 250  | 1000 | 1000 | 1000        | 1000            | 1000                               |  |
| Max № of System Zones                        | 250  | 1000 | 1000 | 1000        | 1000            | 1000                               |  |
| Max № of Points                              | 300  | 1000 | 1000 | 2           | 9               | 65                                 |  |
| № of On-board Points                         | 31   | 43   | 56   | 2           | 9               | 9                                  |  |
| № of On-board Sounders                       | 2    | 2    | 4    | 0           | 0               | 0                                  |  |
| № of On-board Relays (including O/C Outputs) | 4    | 10   | 10   | 0           | 0               | 0                                  |  |
| № of Switch Inputs                           | 8    | 8    | 8    | 1           | 8 <sup>20</sup> | 8 <sup>20</sup> (56) <sup>21</sup> | See footnotes  |
| Max № of Time Clocks                         | 3    | 10   | 10   | --          | 3               | 3                                  |  |
| Max № of Ringing Styles                      | 10   | 20   | 20   | 10          | 10              | 10                                 |  |
| Max № of Output Groups                       | 200  | 200  | 200  | 200         | 200             | 200                                |  |
| Max № of Output Group Lines                  | 250  | 1150 | 1150 | 250         | 250             | 250                                | Requires PC CONFIG to define more than one line per Output Group |
| Max № of Passwords                           | 12   | 12   | 12   | 12          | 12              | 12                                 |  |
| Max № of Sectors Available                   | 50   | 50   | 50   | 50          | 50              | 50                                 | PC CONFIG Only   |
| Max № of Input Events                        | 100  | 250  | 250  | 100         | 100             | 250                                | PC CONFIG Only   |
| Max № of Logic Blocks                        | 50   | 100  | 100  | 50          | 50              | 50                                 | PC CONFIG Only   |
| Max № of Logic Terms <sup>22</sup>           | 100  | 500  | 500  | 100         | 100             | 100                                | PC CONFIG Only   |
| Max First Loop №                             | 20   | 19   | 17   | --          | --              | --                                 | PC CONFIG Only   |

<sup>20</sup> Only available if a display card is fitted.

<sup>21</sup> Requires PC CONFIG to define the 50-Way I/O card for additional inputs.

<sup>22</sup> Max № of logic terms available to the user depends upon the number of logic blocks defined. Each logic block requires a terminator term. This terminator uses up one of the available logic terms. Therefore, the number of logic terms available for use will be the Max № of Logic terms – the № of Logic blocks used – for example, using 20 logic blocks in an Mx-4400 will give 500-20=480 Logic Terms available to use.

Doc Number: 680-014  
Revision: 15



Advanced Electronics Ltd  
The Bridges, Balliol Business Park, Newcastle upon Tyne, NE12 8EW. UK

Tel: +44 (0)345 894 7000

Email: [sales@advancedco.com](mailto:sales@advancedco.com)

Web: [www.advancedco.com](http://www.advancedco.com)